

*Main Catalogue*

# ISR

## Brakes

*For Street and Racing*

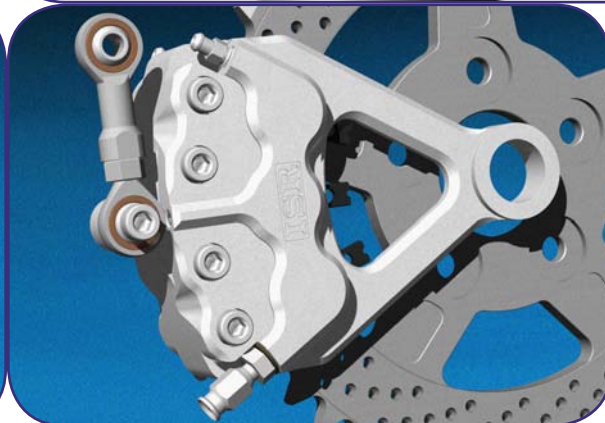
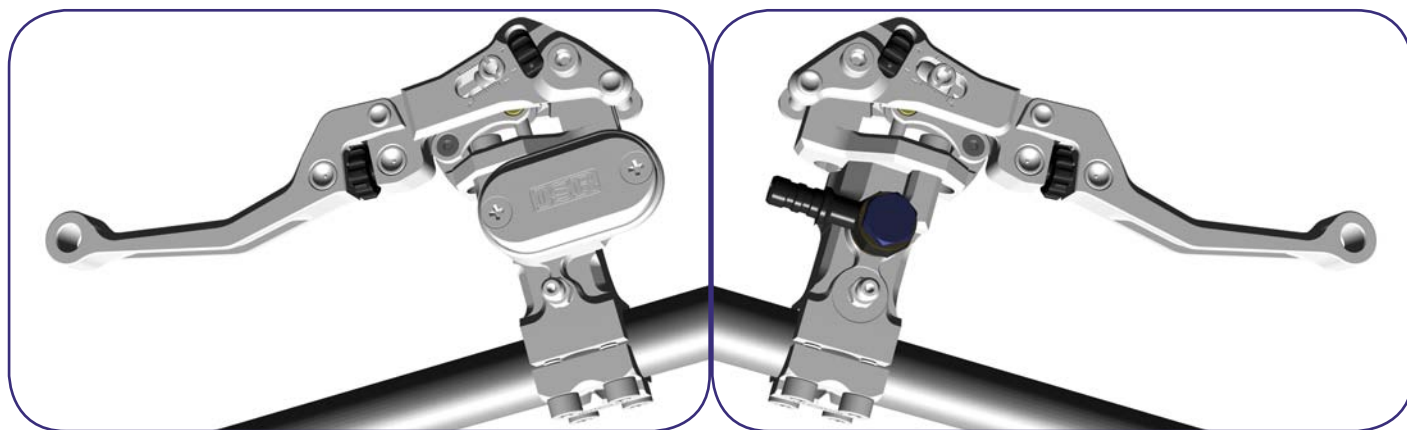



## INTRO TO THE CATALOGUE

I am proud to introduce to you this catalogue as this is a major marketing tool for you as a retailer and for us as manufacturers .

In studying this catalogue you will notice that we have developed our range of products insofar as we begin at low cost , simple solutions , end of the market and go on to the high tech , competitive , racing end of said market.

**Acke Rising**  
**ISR-Motorcyckel AB.**

The fantastic photography is by multiple prize winning photographer **Gösta Rising** (cousins are wonderful things!). The catalogue has been compiled and designed by long time friend **Kim elDine**.

# PAGE INDEX

## 1: Wheel hubs

13 Family



## 2: Master cylinders

21-005

Front Master

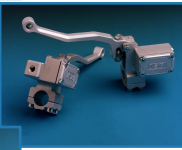

21-006

Front Master



21-009

Rear Master



21-010

Rear Master



21-011

Front Master



21-012

Front Master

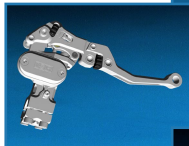

21-013

Front Master



21-014

Front Master

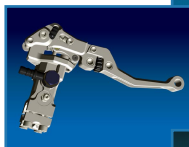

21-137

Adjustable grip



## 3: Calipers

22-023

Two piston Ø43



22-025

Four piston Ø34



22-026

Two piston Ø43



22-027

Two piston Ø34



22-028

Two piston Ø34



22-029

Two piston Ø34



22-030

Two piston Ø43



22-032

Six piston Ø30



22-033

Two piston Ø43



22-034

Six piston Ø25



22-036

Two piston Ø25



22-042

Six piston Ø30



22-043

Four piston Ø25

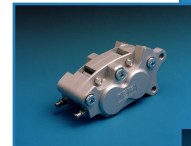

22-044

Six piston Ø30



22-046

Six piston Ø25

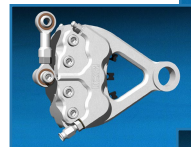

22-047

Four piston Ø34



22-048

Four piston Ø25



## 4: Discs & Hubs

22 Series Kits



23 Series Discs



## 5: Cable levers

71-003

Cable levers 1" (HD)



71-004

Cable levers 22mm



## Electrics

73 Family





# The family of -13



**T**his new venture from us at ISR is to offer bikers of all categories a novel approach to wheel hubs .

In our new series of hubs we offer integral disc carriers and large bearings , something which lends itself both to clean design, low weight and , in most cases , fixed spacers.

These our hubs come in three variants , two front ones and one rear . The larger front one is intended for performance oriented sports and custom bikes , featuring full floating 320mm discs , whereas the hub for the chopper market sports semi floating 260mm discs.

The rear hub with a semi floating 250mm disc also includes a cushion drive.

**13-020-OA:** Front , 260mm disc.

**13-021-OA:** Rear , 250mm disc.

**13-026-OA:** Front , 320mm disc.



**F**ront chopper wheel hub for 40 spokes , with integral disc carrier for two semi floating 260mm discs for our 22-043 mini four piston calipers.

Bearings have a 25mm bore to be sleeved down to selected spindle diameter through fixed spacers.

# ISR

PART NUMBER : 13-020-0A

## 40 SPOKE WHEEL HUB W. INTEGRAL SEMI FLOATING DISCS

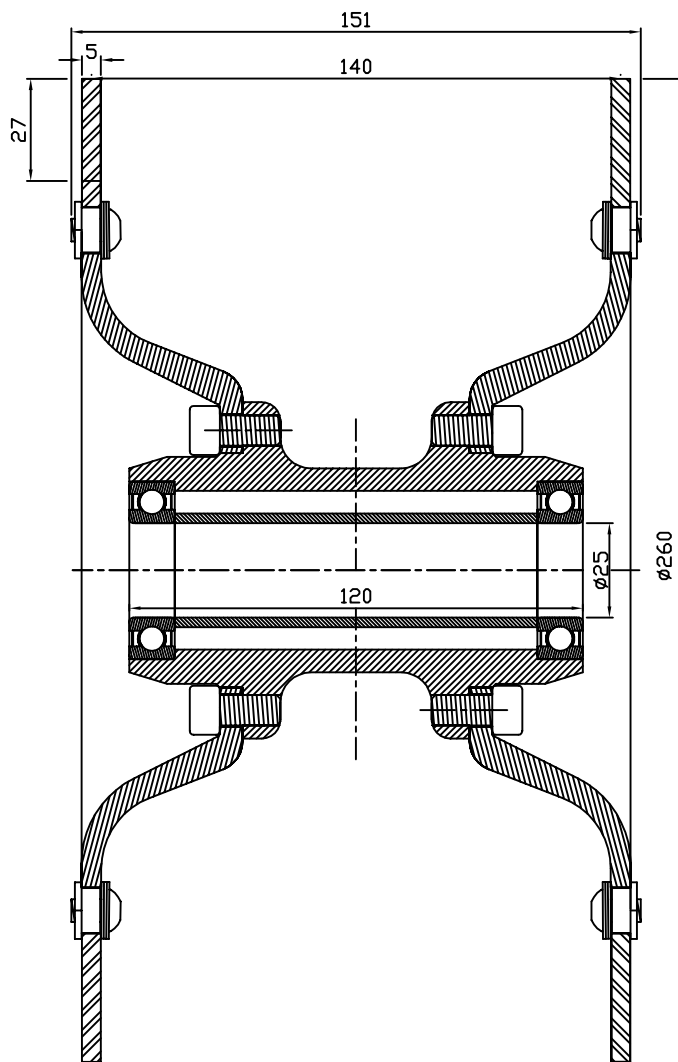

### Technical data:

Dimensions:

Assembly Width: 151 mm

Disc Ø260 mm

Weight:

3.70 kg

Surface finish:

Clear anodised

Designed for 4 mm spokes.

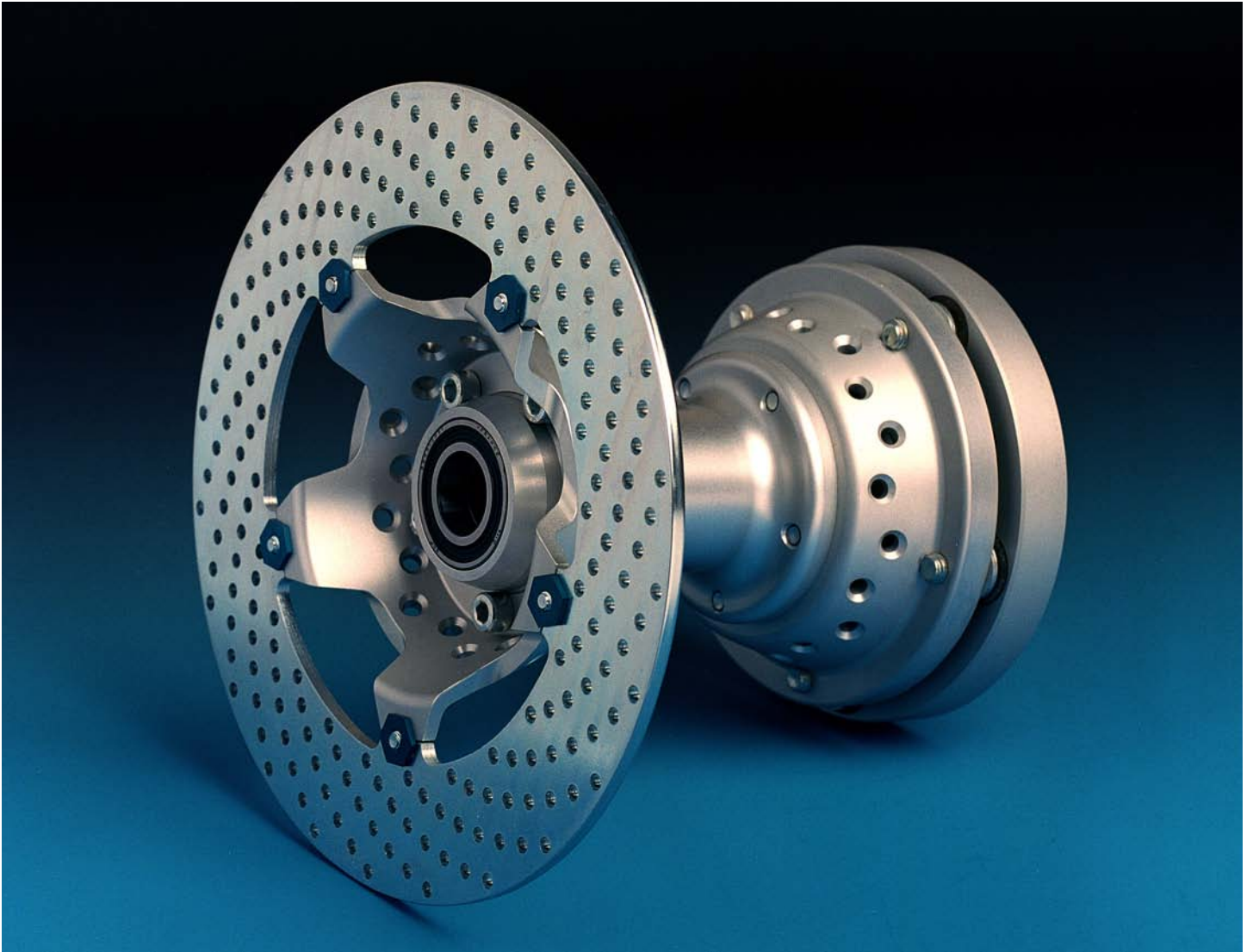

**R**ear hub with integral carrier with 250mm semi floating disc and cushion drive. Suggested calipers for a sports bikes are 22-029-OC/OD, or in the case of choppers and custom bikes the 22-025.

Bearings are of 25mm bore to be sleeved down to selected spindle diameter by means of fixed spacers.

# ISR

PART NUMBER : 13-021-0A

## 40 SPOKE WHEEL HUB REAR W. INTEGRAL SEMI FLOATING DISC

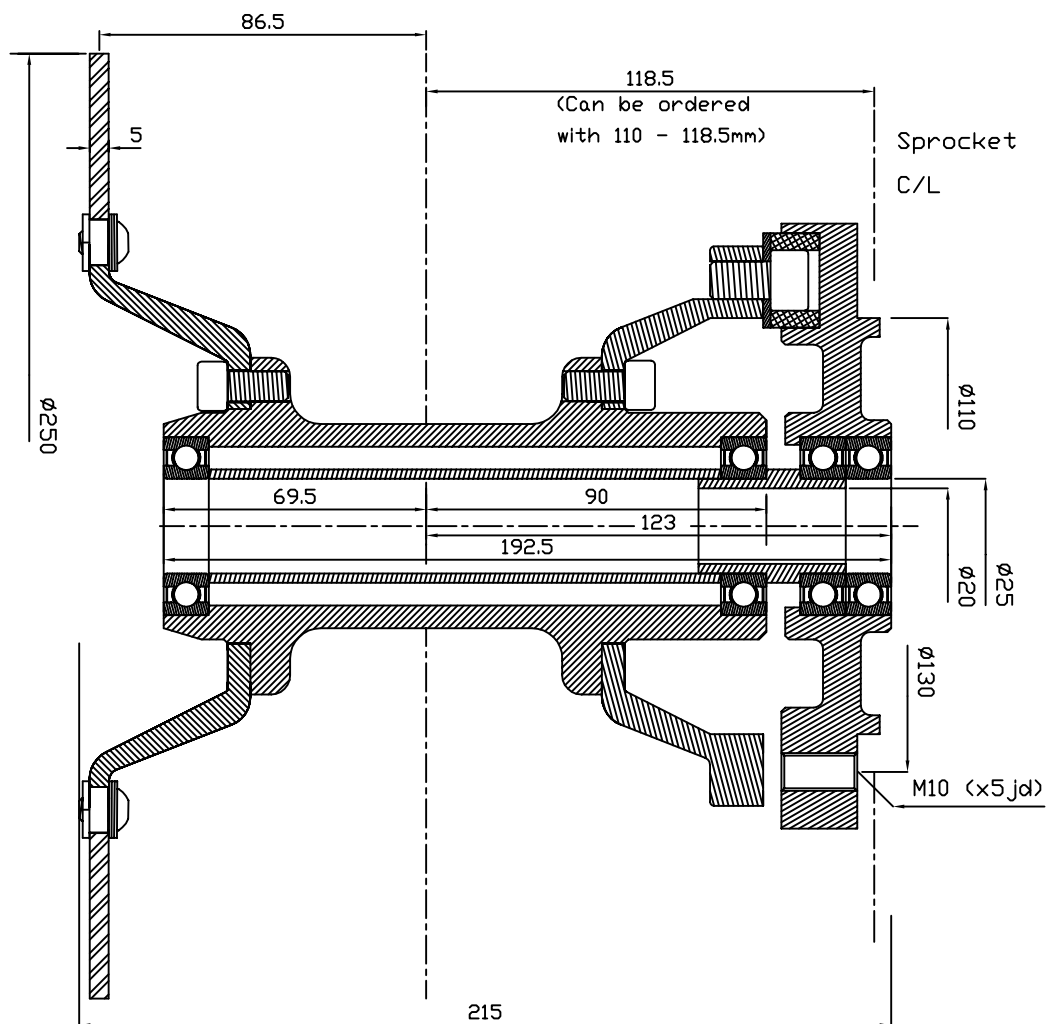

### Technical data:

Dimensions:

Assembly Width: 215 mm

Disc Ø250 mm

Weight:

4.40 kg

Surface finish:

Clear anodised

Designed for 4 mm spokes.



**F**ront wheel hub for 40 spokes , with integral disc carrier for two full floating 320mm discs for our big six piston calipers. This setup is intended for performance oriented sports and custom bikes .

Bearings have a 25mm bore to be sleeved down to selected spindle diameter through fixed spacers.

# ISR

PART NUMBER : 13-026-0A

## 40 SPOKE WHEEL HUB W. INTEGRAL FULL FLOATING DISCS

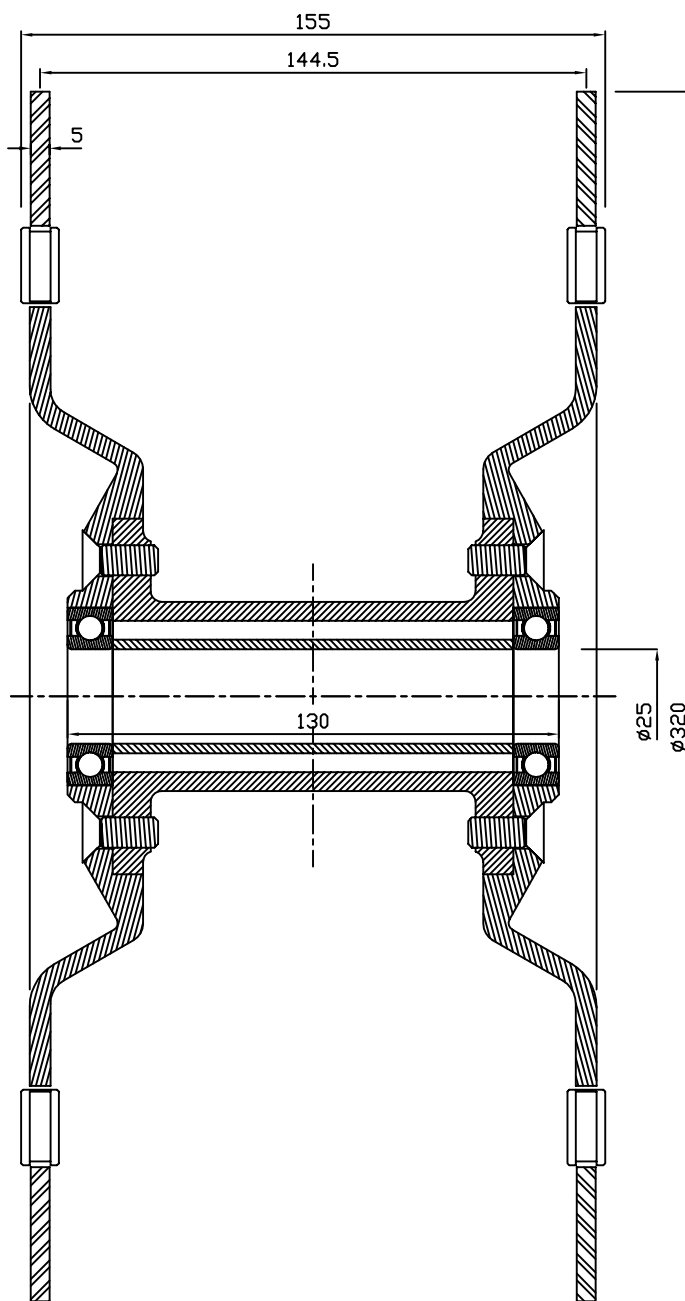

### Technical data:

Dimensions:

Assembly Width: 155 mm

Disc  $\varnothing$ 320 mm

Weight:

4.10 kg

Surface finish:

Clear anodised

Designed for 4 mm spokes.



# 21-005-0A-0B

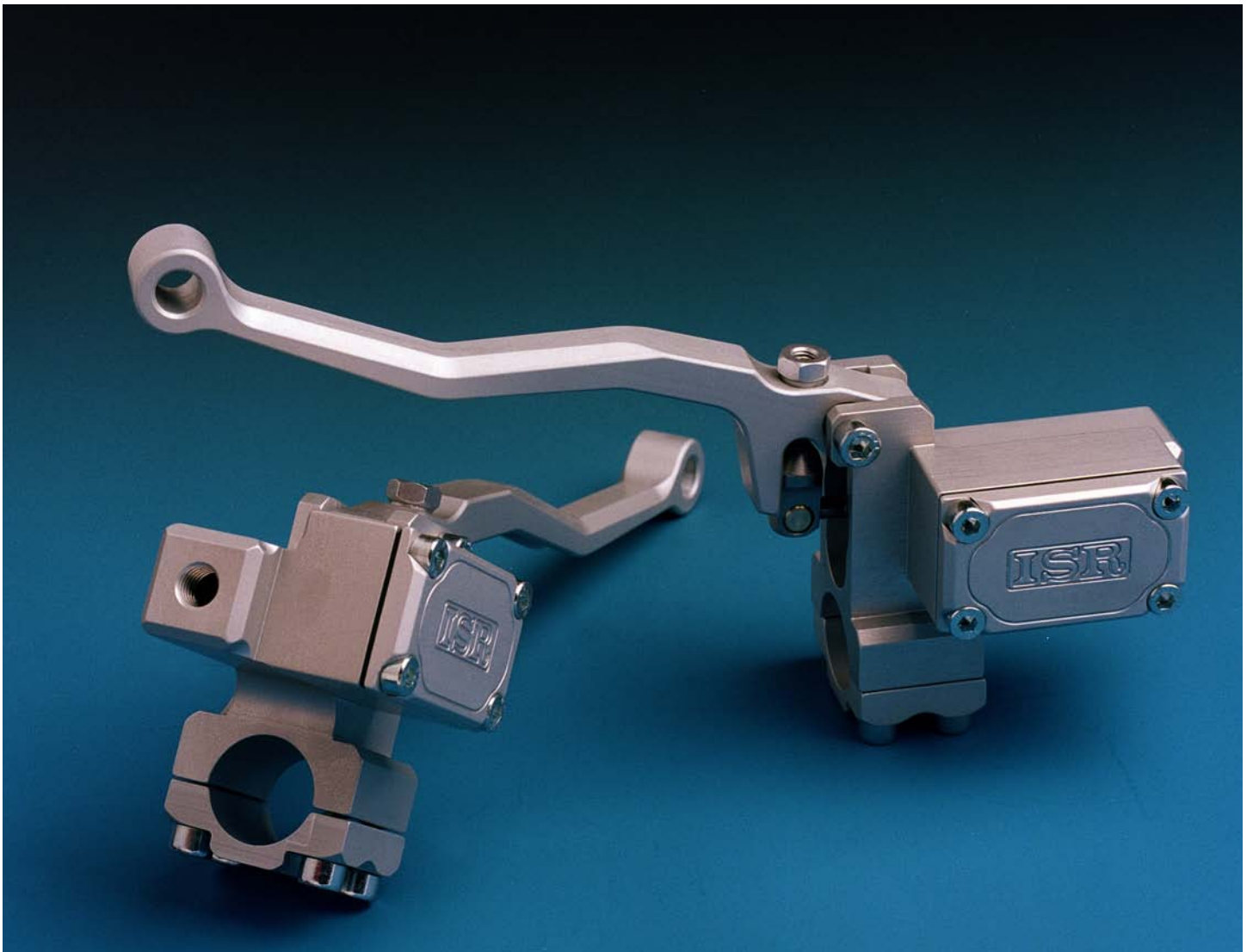

This master cylinder comes in two diameters , 14mm and 17,5mm. The smaller diameter is suitable for use with a single caliper or with a pair of twin piston calipers with piston diameters up to 34mm. It also works equally well with a pair of the 22-043 four piston caliper.

The larger bore is more suitable for use with a pair of twin 43mm piston calipers or twin four or six piston calipers .

The grip has a leverage adjustment , to further personalize the feel of the brake , moreover, there is also the possibility to order these with the 21-137-OA lever with adjustable reach.

# ISR

PART NUMBER : 21-005-0A (RH)  
21-005-0B (LH)  
21-005-0C (RH)  
21-005-0D (LH)

21-005-0A

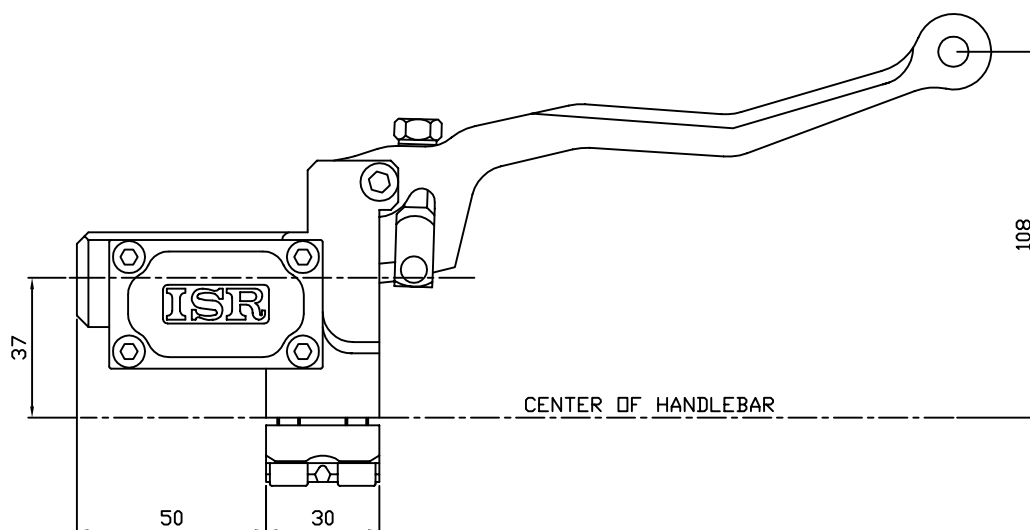
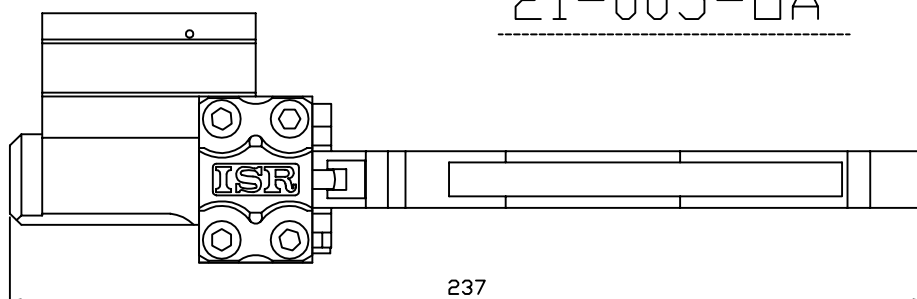

## Technical data:

Cylinder diameter OA/OB:	17.5mm
Cylinder diameter OC/OD:	14mm
Reservoir capacity:	18cm <sup>3</sup>
Hydraulic thread:	M10x1.25
Weight:	0.42kg
Leverage ratio:	5:1-3,8:1
Surface finish:	Clear anodised
Handlebar size:	ø25.4mm

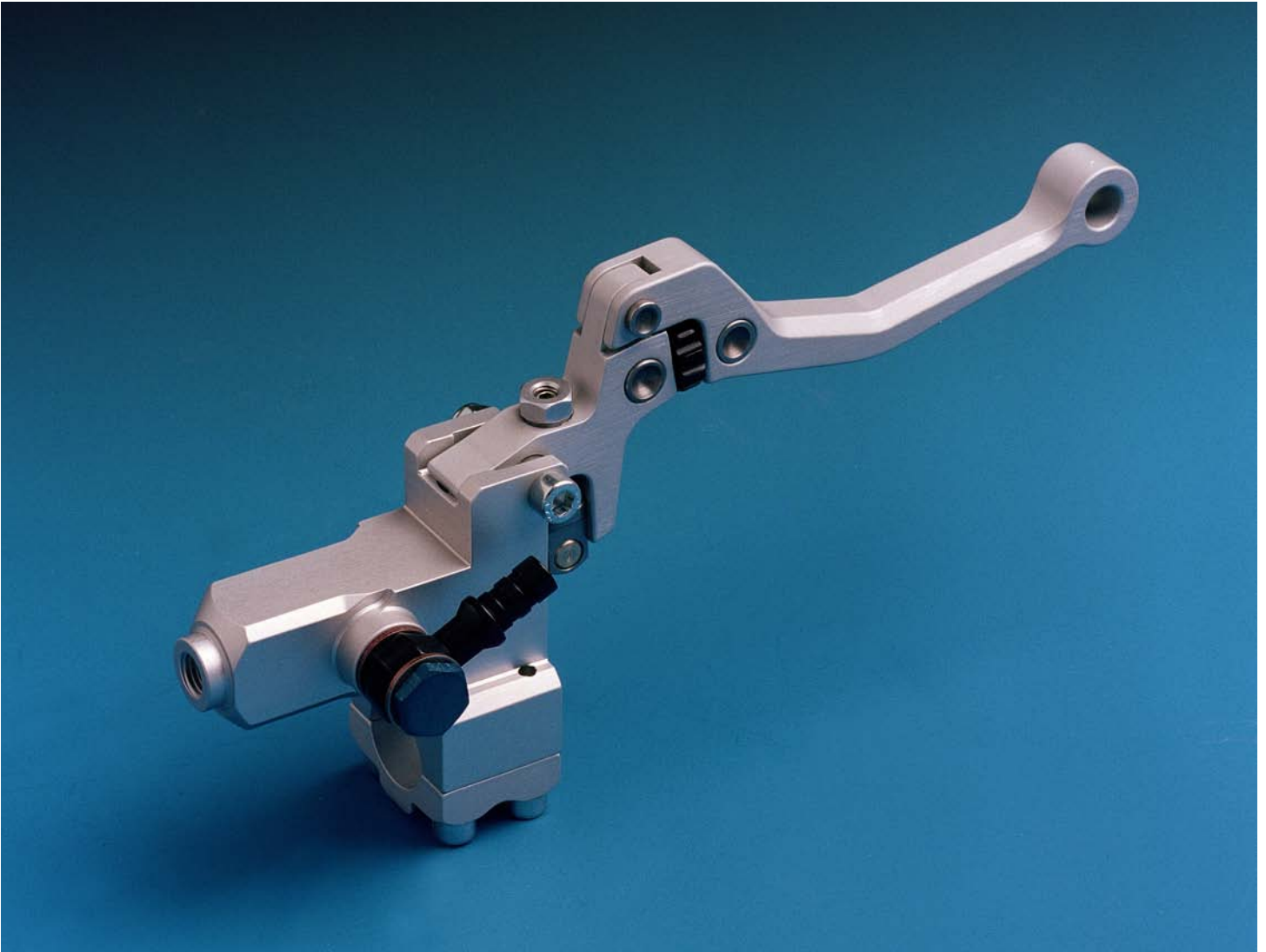

**T**his master cylinder comes in two versions ; 14mm and 17,5mm .

The smaller diameter is suitable for use with a single caliper or with a pair of twin piston calipers with diameters up to 34mm.

It works equally well with a pair of the 22-043 four piston calipers.

The larger bore is more suitable for use with a pair of twin 43mm piston calipers or twin four or six piston calipers .

The grip has a leverage adjustment , moreover in order to further personalize the feel of the brake , there is also the possibility to order it with the 21-137-OA adjustable reach lever , as shown above.

# ISR

PART NUMBER : 21-006-0A (RH)  
21-006-0B (LH)  
21-006-0C (RH)  
21-006-0D (LH)

21-006-□A

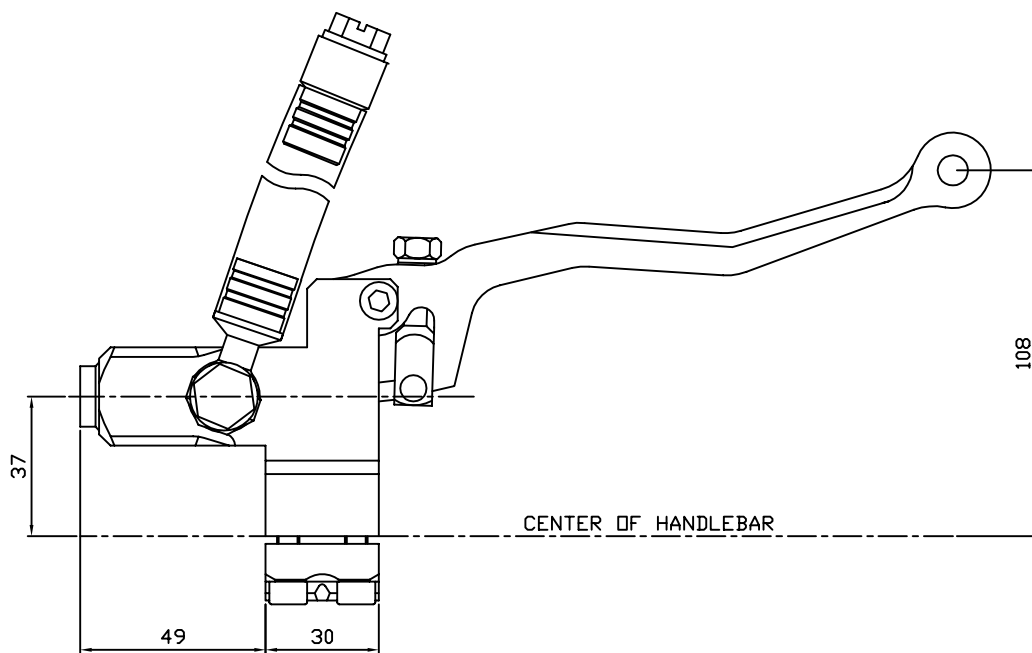
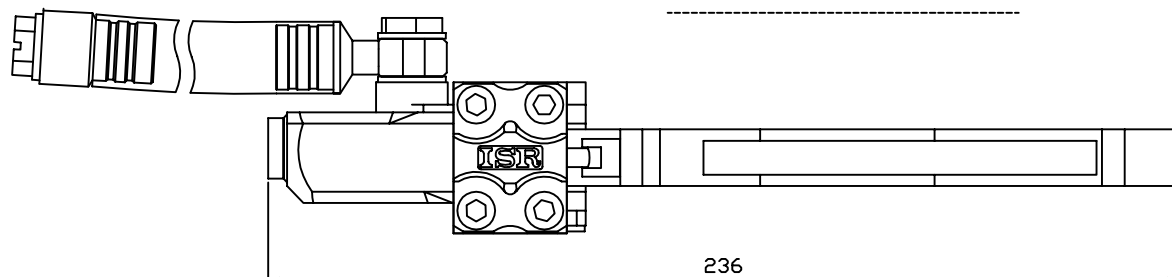

## Technical data:

Cylinder diameter OA/OB:	17.5mm
Cylinder diameter OC/OD:	14mm
Reservoir capacity:	50cm <sup>3</sup>
Hydraulic thread:	M10x1.25
Weight:	0.42kg
Leverage ratio:	5:1-3,8:1
Surface finish:	Clear anodised
Handlebar size:	∅22mm



# 21-009-0A



**M**aster cylinder intended for Harley rear use , but has proven itself useful in a variety of applications, industrial as well as vehicular . It is compatible with all ISR calipers .

Please note that in constructing a brake system , always try to mount the master cylinder higher than its caliper.

# ISR

PART NUMBER : 2I-009-0A  
2I-009-0B  
2I-009-0D

## 2I-009-0A - (HD)

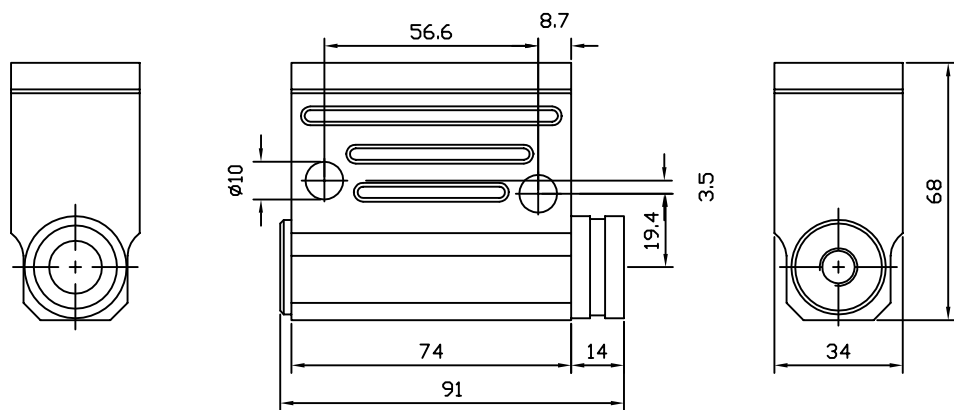

INSIDE VIEW OF PISTON HOLE  
FOR PUSHROD

## 2I-009-0B/OD - (UNIVERSAL)

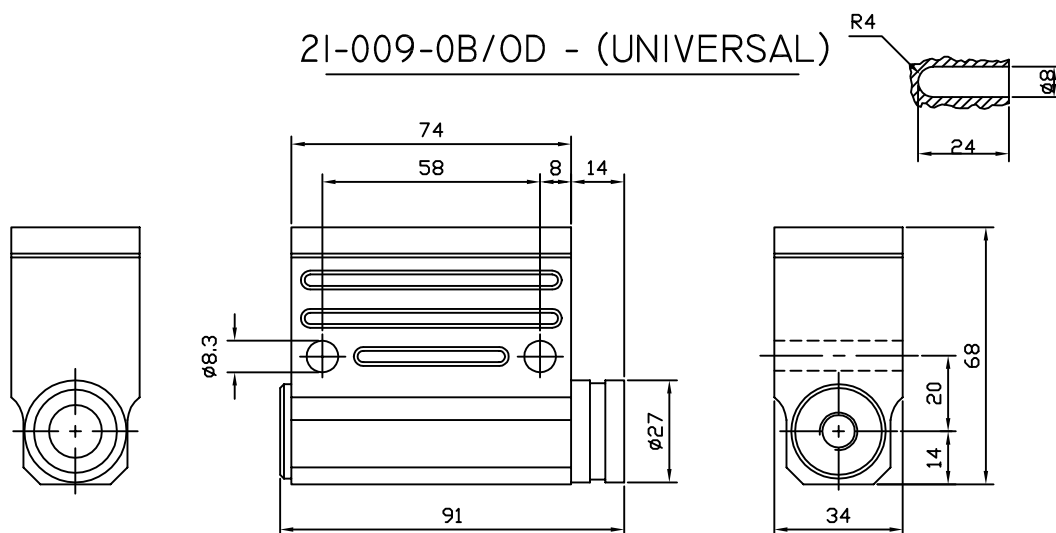

### Technical data:

Cylinder diameter:-0A/0B	14mm
Cylinder diameter:-0D	17.5mm
Maximum allowed stroke:	16mm
Max displaced volume:-0A/0B	2.2 cm <sup>3</sup>
Max displaced volume:-0D	3.4 cm <sup>3</sup>
Reservoir capacity:	40 cm <sup>3</sup>
Hydraulic thread:	M10x1.25
Weight:	0.29kg
Surface finish:	Clear anodised



# The 21-010 Family

-OE

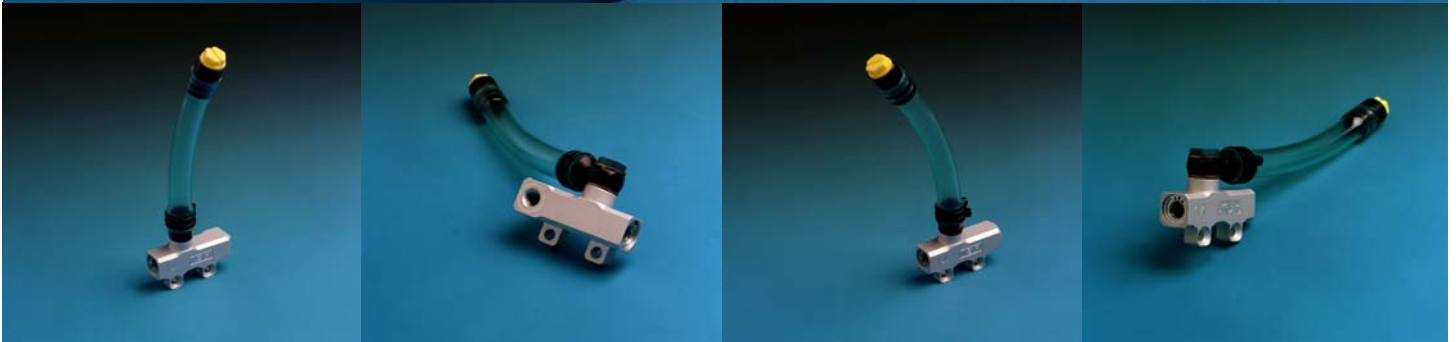

-OA

-OB

-OC

-OD

This neat little rear master cylinder is intended for sports and racing bikes . There are three bodies and two reservoir types to chose from . Outlet coaxial or in 90° to bore .Compatible with twin 34mm piston calipers or four 25mm piston calipers .

- OA: Outlet 90° to axis , horizontal
- OB: Outlet 90° to axis , horizontal
- OC: Outlet co-axial
- OD: Outlet co-axial
- OE: Outlet co-axial

# ISR

PART NUMBER : 21-010-0A  
21-010-0B

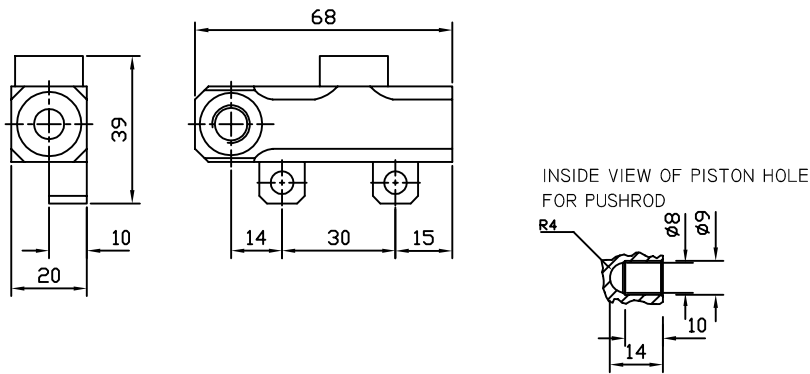

21-010-0A

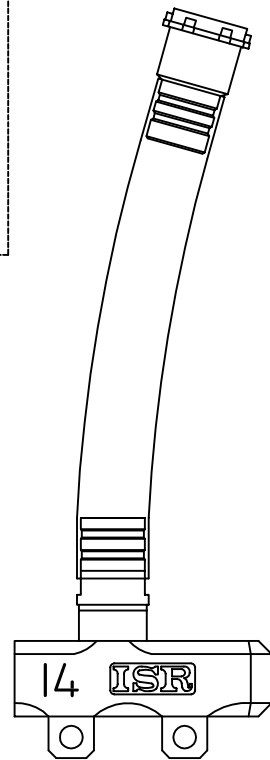

21-010-0B

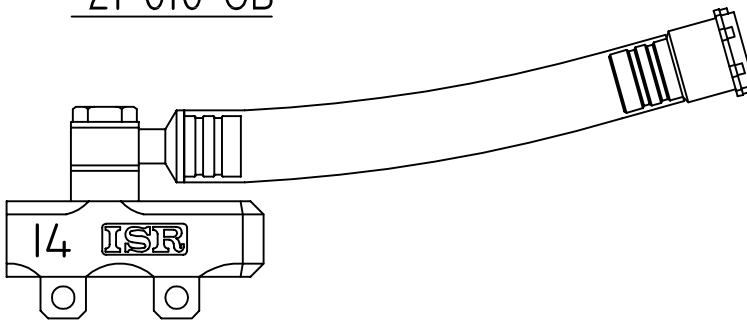

## Technical data:

Cylinder diameter:	14mm
Maximum allowed stroke:	14mm
Max displaced volume:	1.8cm <sup>3</sup>
Reservoir capacity:	22cm <sup>3</sup>
Hydraulic thread:	M10x1.25
Weight:	0.12kg
Surface finish:	Clear anodised

# ISR

PART NUMBER : 21-010-0C  
21-010-0D

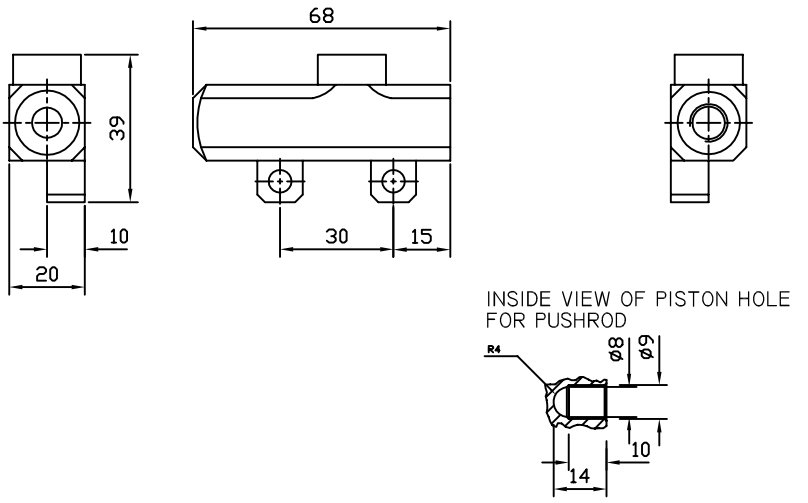

21-010-0C

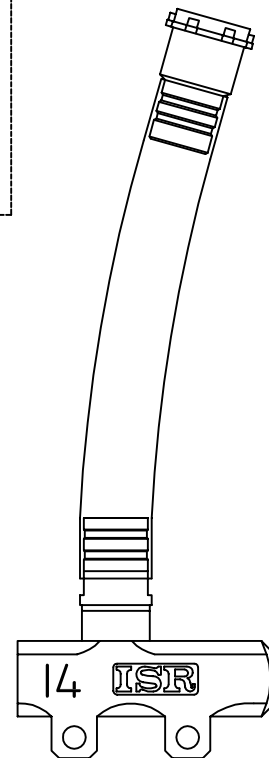

21-010-0D

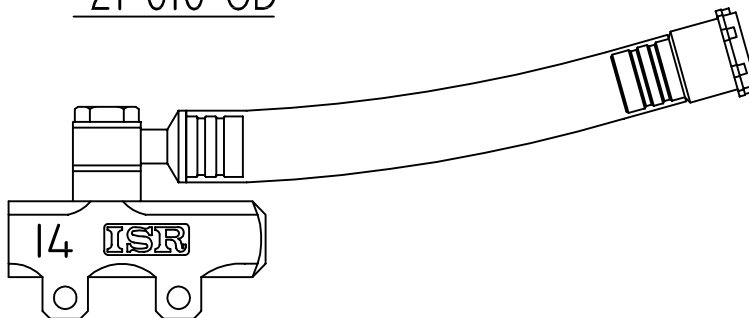

## Technical data:

Cylinder diameter:	14mm
Maximum allowed stroke:	18mm
Max displaced volume:	2.5cm <sup>3</sup>
Reservoir capacity:	22cm <sup>3</sup>
Hydraulic thread:	M10x1.25
Weight:	0.12kg
Surface finish:	Clear anodised

# ISR

PART NUMBER : 2I-010-OE

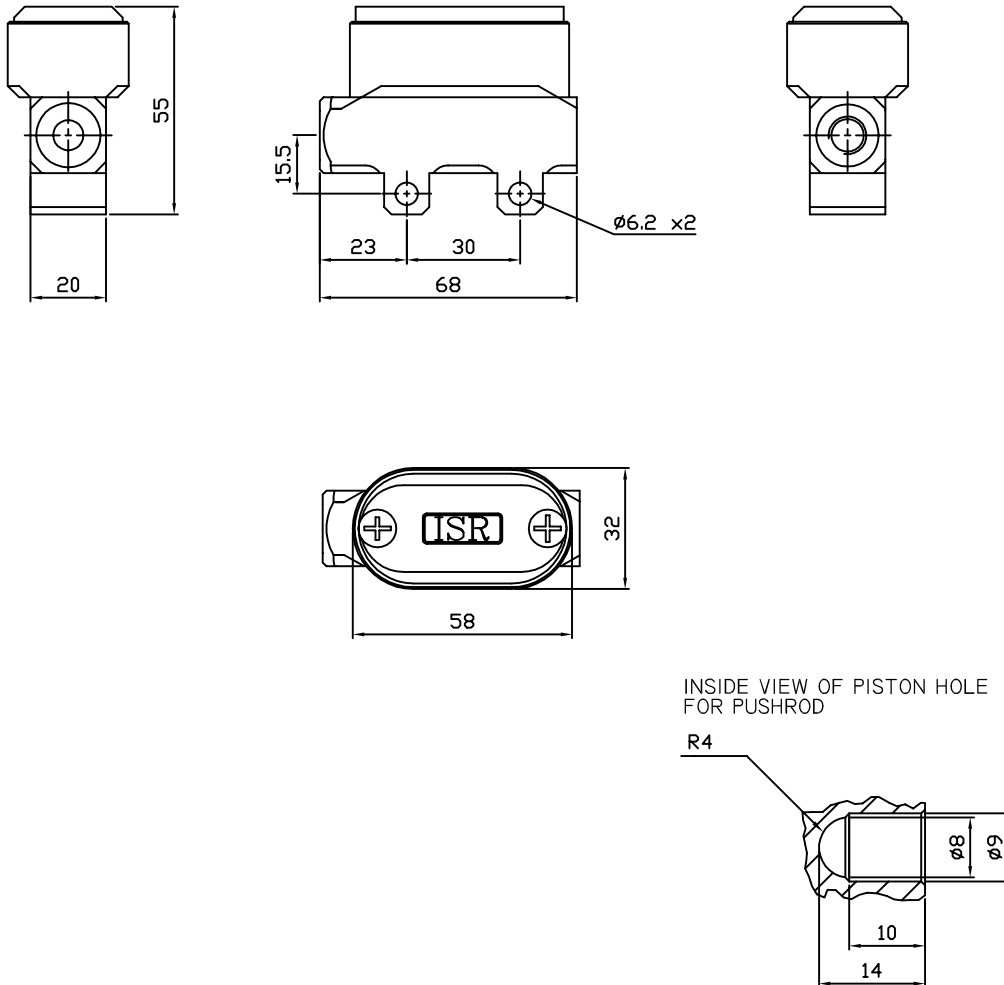

## Technical data:

Cylinder diameter:	14mm
Maximum allowed stroke:	18mm
Max displaced volume:	2.5cm <sup>3</sup>
Reservoir capacity:	11cm <sup>3</sup>
Hydraulic thread:	M10x1.25
Weight:	0.12kg
Surface finish:	Clear anodised



# 21-011-0B-AB



**T**his master cylinder comes in two diameters , 14mm and 17,5mm , for clutch and brake use. The smaller diameter is suitable for use with a single caliper or with a pair of twin piston calipers with piston diameters up to 34mm. It also works equally well with a pair of the 22-043 four piston caliper. The larger bore is more suitable for use with a pair of twin 43mm piston calipers or twin four or six piston calipers .

The grip has a leverage adjustment , to further personalize the feel of the brake , moreover, as on the unit in the rear of the picture , there is also the possibility to order this with the 21-137-OA lever with additional adjustable reach.

# ISR

PART NUMBER : 2I-0II-0A (RH)  
2I-0II-0B (LH)  
2I-0II-0C (RH)  
2I-0II-0D (LH)  
2I-0II-0I (RH)  
2I-0II-0J (LH)  
2I-0II-0K (RH)  
2I-0II-0L (LH)

21-011-□A

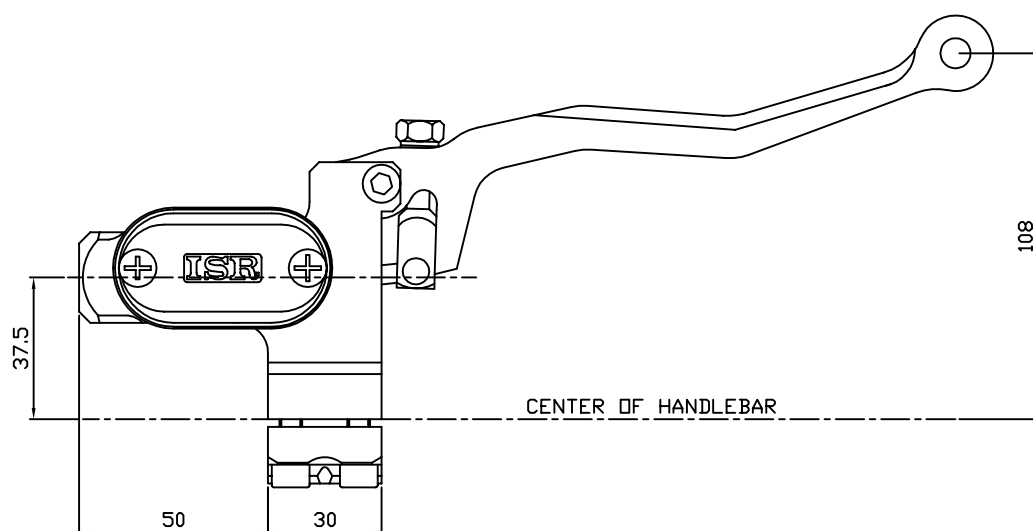
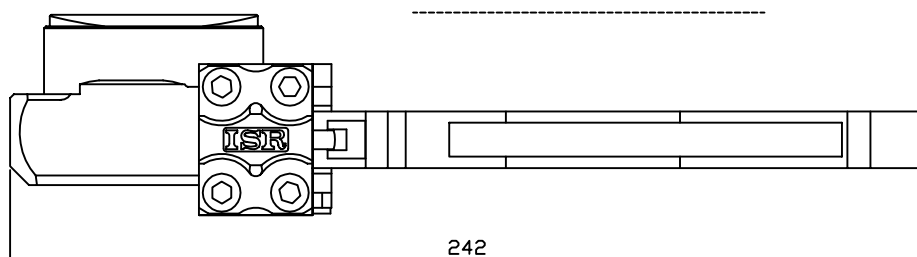

## Technical data:

Cylinder diameter 0A,0B,0I,0J:	17.5mm
Cylinder diameter 0C,0D,0K,0L:	14mm
Reservoir capacity:	11cm <sup>3</sup>
Hydraulic thread:	M10x1.25
Weight:	0.39kg
Leverage ratio:	5:1-3,8:1
Surface finish:	Clear anodised
Handlebar size; 0A-0D:	∅25.4mm
Handlebar size; 0I-0L:	∅22mm

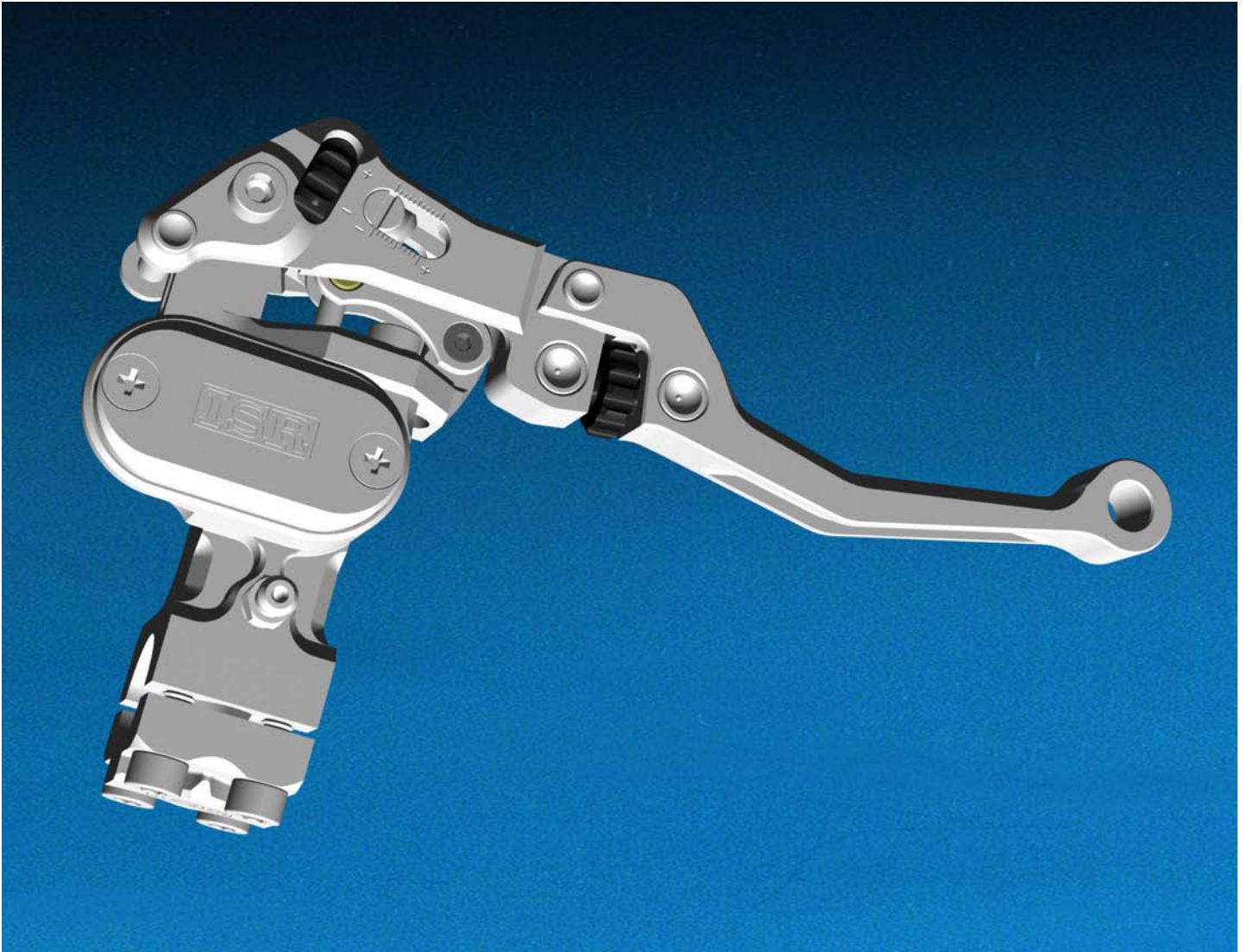

## **R**adial Brake and Clutch master cylinder.

This master cylinder is intended for street fighters, supermotard and similar bikes.

Thanks to the innovative design, it has a very large range of brake power adjustment.

It also has a quick change mount for the lever assembly.

Adjustable grip reach handle is standard.

Very easy to adjust, both power range and grip reach, no tools needed.

Available in 15.87mm.

# ISR

PART NUMBER : 21-012-0A (RH)  
21-012-0B (LH)  
21-012-0C (RH)  
21-012-0D (LH)

21-012-0A

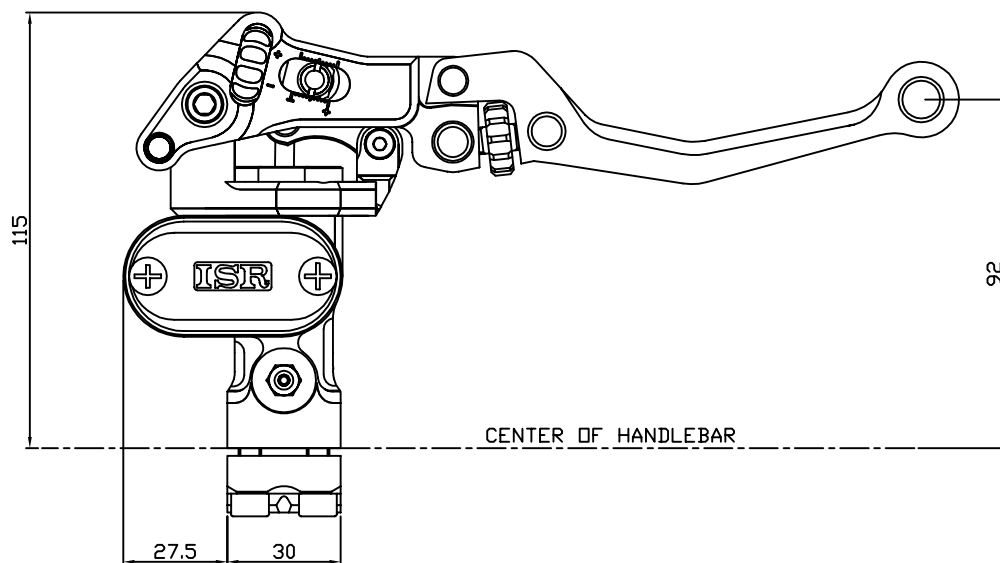
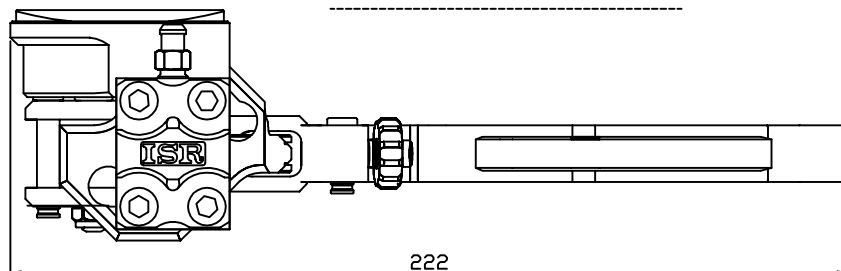

## Technical data:

Cylinder diameter OA/OB:	ø17.5mm
Cylinder diameter OC/OD:	ø15.87mm
Reservoir capacity:	10cm <sup>3</sup>
Hydraulic thread:	M10x1.25
Weight:	0.46kg
Leverage ratio:	5,2:1-3:1
Surface finish:	Clear anodised
Handlebar size:	ø22mm



# 21-013-0A



**R**adial Brake and Clutch master cylinder intended for custom machines .  
Almost every surface is curved, only one or two is a straight line.  
This gives the master cylinder a very smooth and pleasing look.  
Available both in 17.5mm and 15.87mm.

# ISR

PART NUMBER : 21-013-0A (RH)  
21-013-0B (LH)  
21-013-0C (RH)  
21-013-0D (LH)

21-013-□A

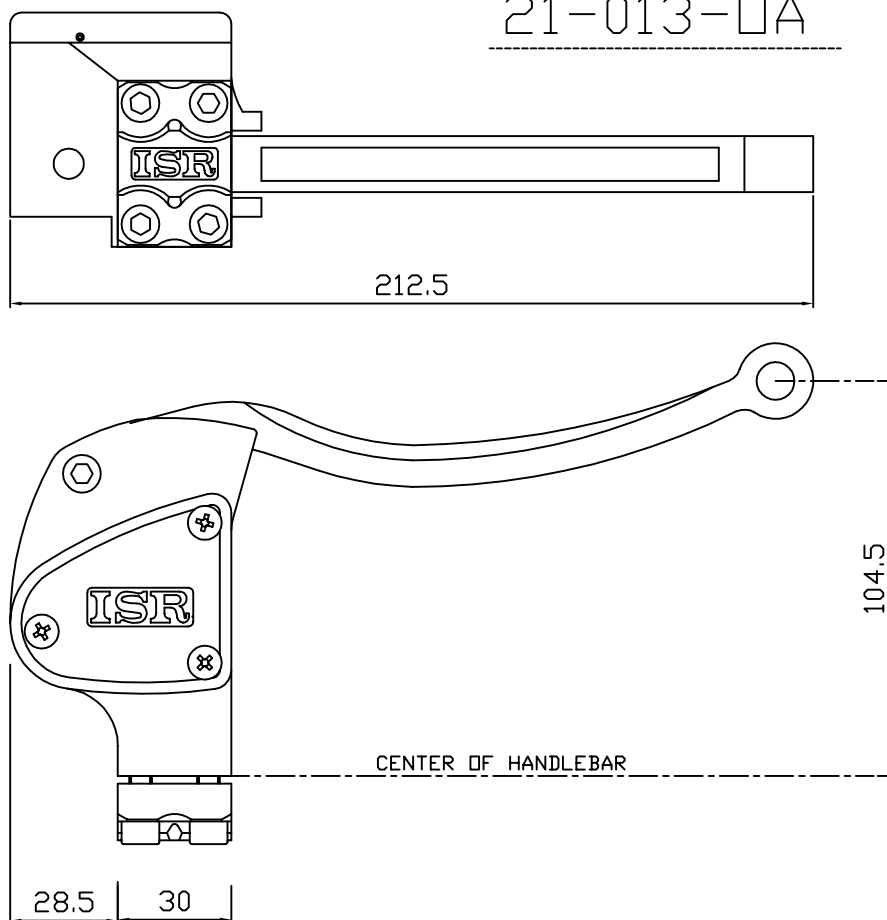

## Technical data:

Cylinder diameter OA/OB:	17.5mm
Cylinder diameter OC/OD:	14mm
Reservoir capacity:	18cm <sup>3</sup>
Hydraulic thread:	M10x1.25
Weight:	0.59kg
Leverage ratio:	3,7:1
Surface finish:	Clear anodised
Handlebar size:	∅25.4mm

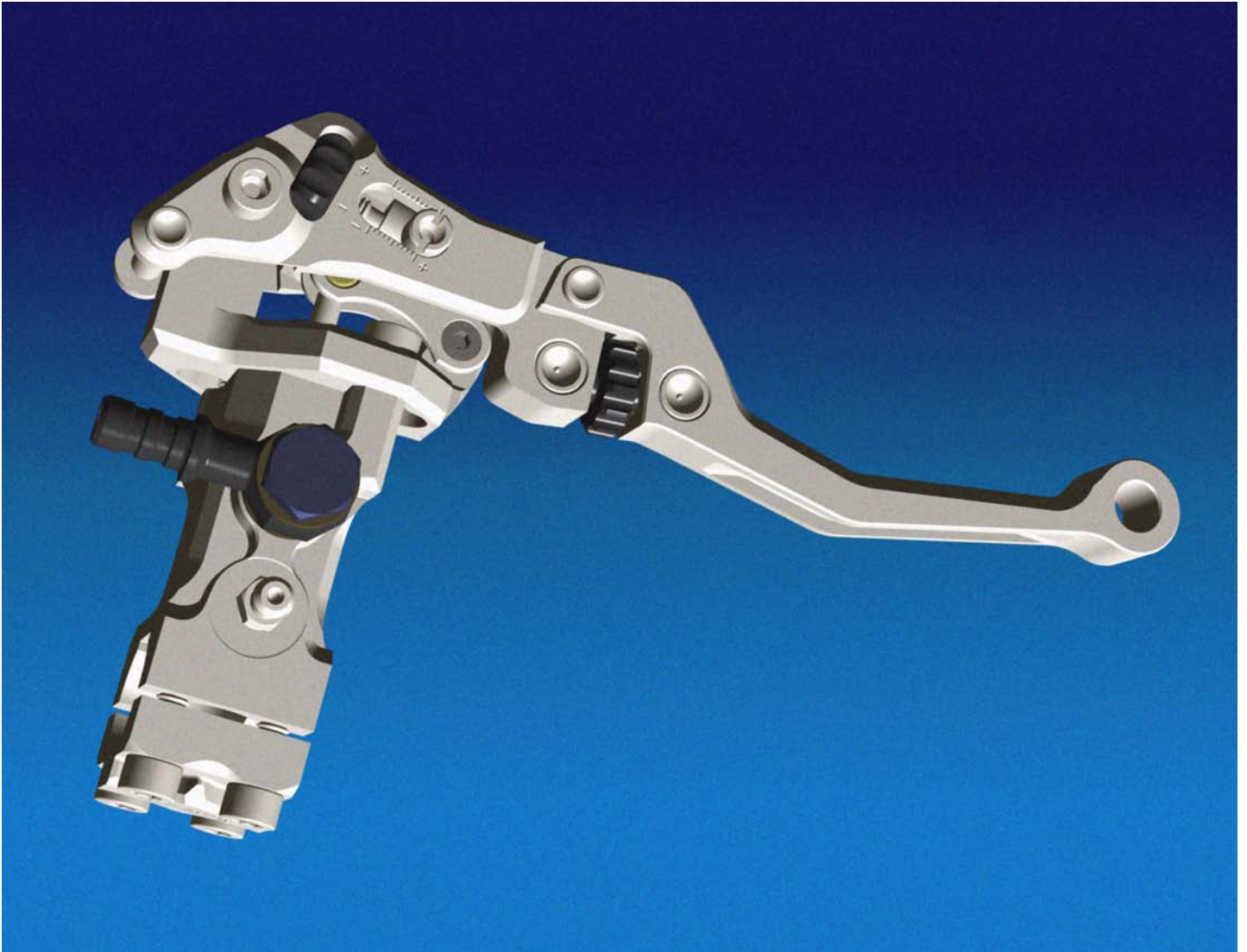

## **R**adial Brake and Clutch master cylinder.

Replaces the 21-007 master cylinder for those who participates in endurance races, because there is no need to bleed the brakes after an accident, thanks to the quick change mounting of the lever assembly.

Thanks to the innovative design, it has a very large range of brake power adjustment. Adjustable grip reach handle is standard.

Very easy to adjust, both power range and grip reach, no tools needed.

Can be used right or left handed by turning the lever assembly.

Available both in 17.5mm and 15.87mm.

# ISR

PART NUMBER : 21-014-0A (RH)  
21-014-0B (LH)  
21-014-0C (RH)  
21-014-0D (LH)

21-014-□A

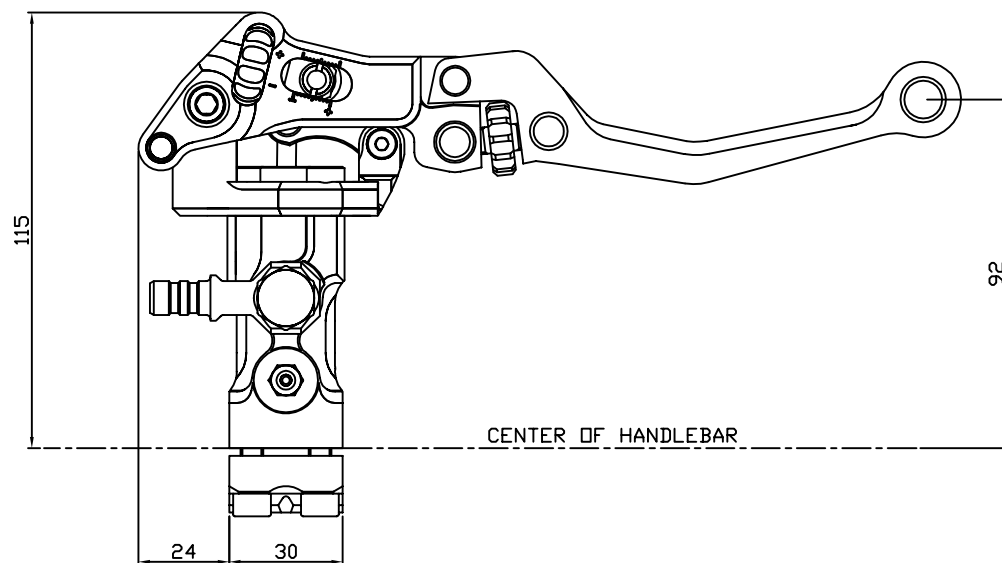
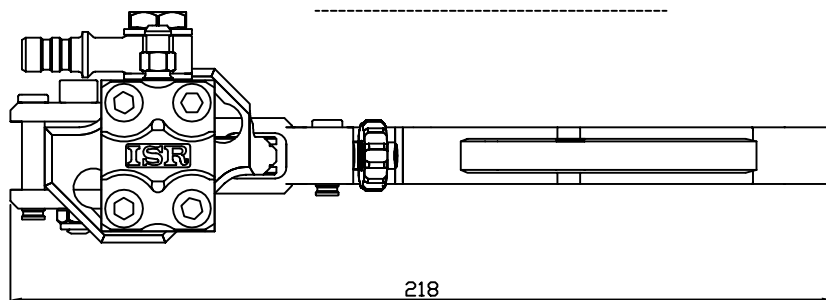

## Technical data:

Cylinder diameter 0A/0B:	∅17.5mm
Cylinder diameter 0C/0D:	∅15.87mm
Reservoir capacity:	Free of choice
Hydraulic thread:	M10x1.25
Weight:	0.44kg
Leverage ratio:	5,2:1-3:1
Surface finish:	Clear anodised
Handlebar size:	∅22mm



**T**wo way adjustable clutch and brake lever , adjustable for both leverage and grip reach.  
The main advantage over ordinary adjustable reach levers is with what ease one can adjust the reach with ones index finger without having to let go of accelerator or handlebars.  
So even in a rather tight racing situation adjustment is feasible.

# ISR

PART NUMBER : 21-137-0A

## ADJUSTABLE LEVER

FITS : 21-005, -006, -007, -011 MASTER CYLINDERS

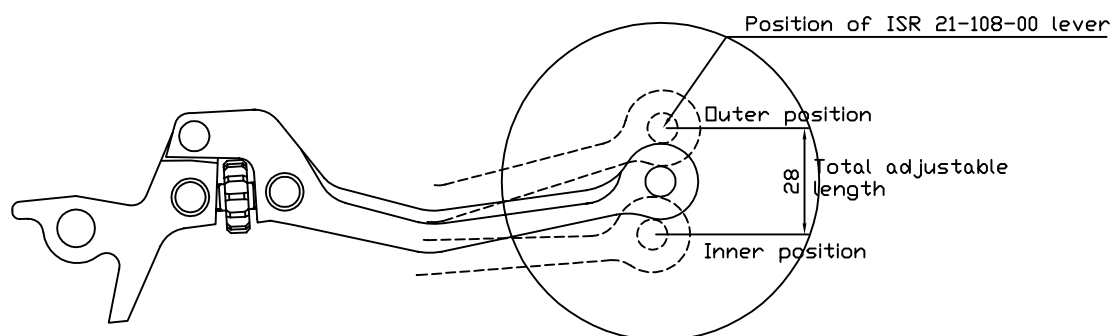

IF YOU WANT THIS LEVER  
WHEN YOU ORDER A MASTER CYLINDER  
THE ORDER NUMBER YOU USE IS FOR EX.  
21-005-AA INSTEAD OF 21-005-0A AND SO ON.



# 22-023-0A

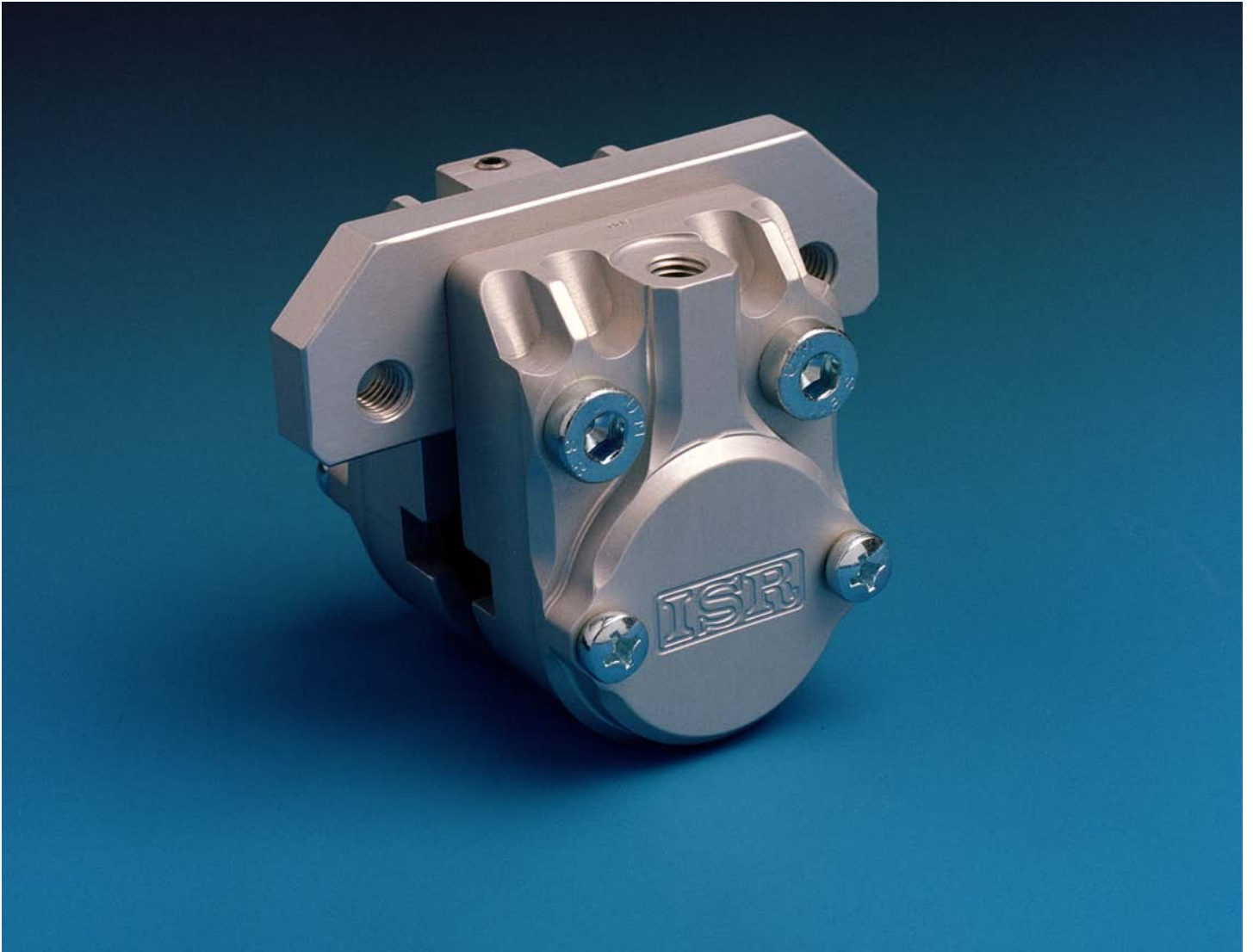

**S**imple , multi adaptable yet powerful little caliper , which can be combined with any conceivable center bracket , can be used left , right and center on most bikes , other vehicles and in industrial applications.

# ISR

PART NUMBER : 22-023-0A

22-023-0A

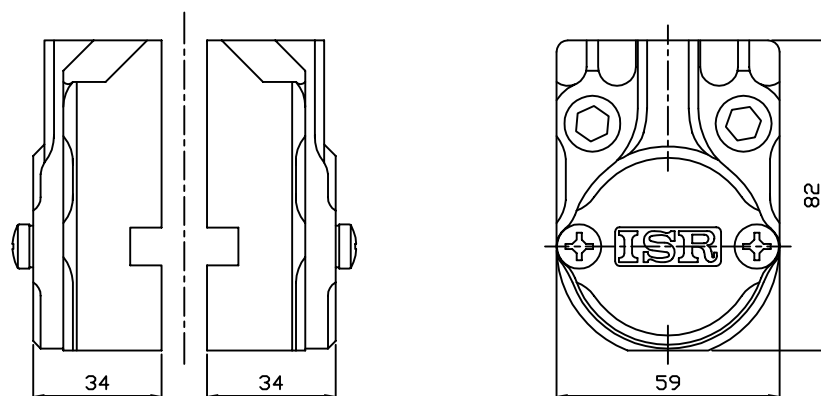

## Technical data:

Piston diameter:	43mm (x2)
Piston material:	Tufam coated aluminium alloy
Pad type:	Ferodo FDB 157 (x2)
Pad area:	18cm <sup>2</sup>
Swept height of disc:	48mm
Disc size:	210mm →
Hydraulic threads:	M10x1.25
Weight incl. pads:	0.55 kg
Surface finish:	Clear anodised



# The 22-025 Family

-AC

-AA

-OK

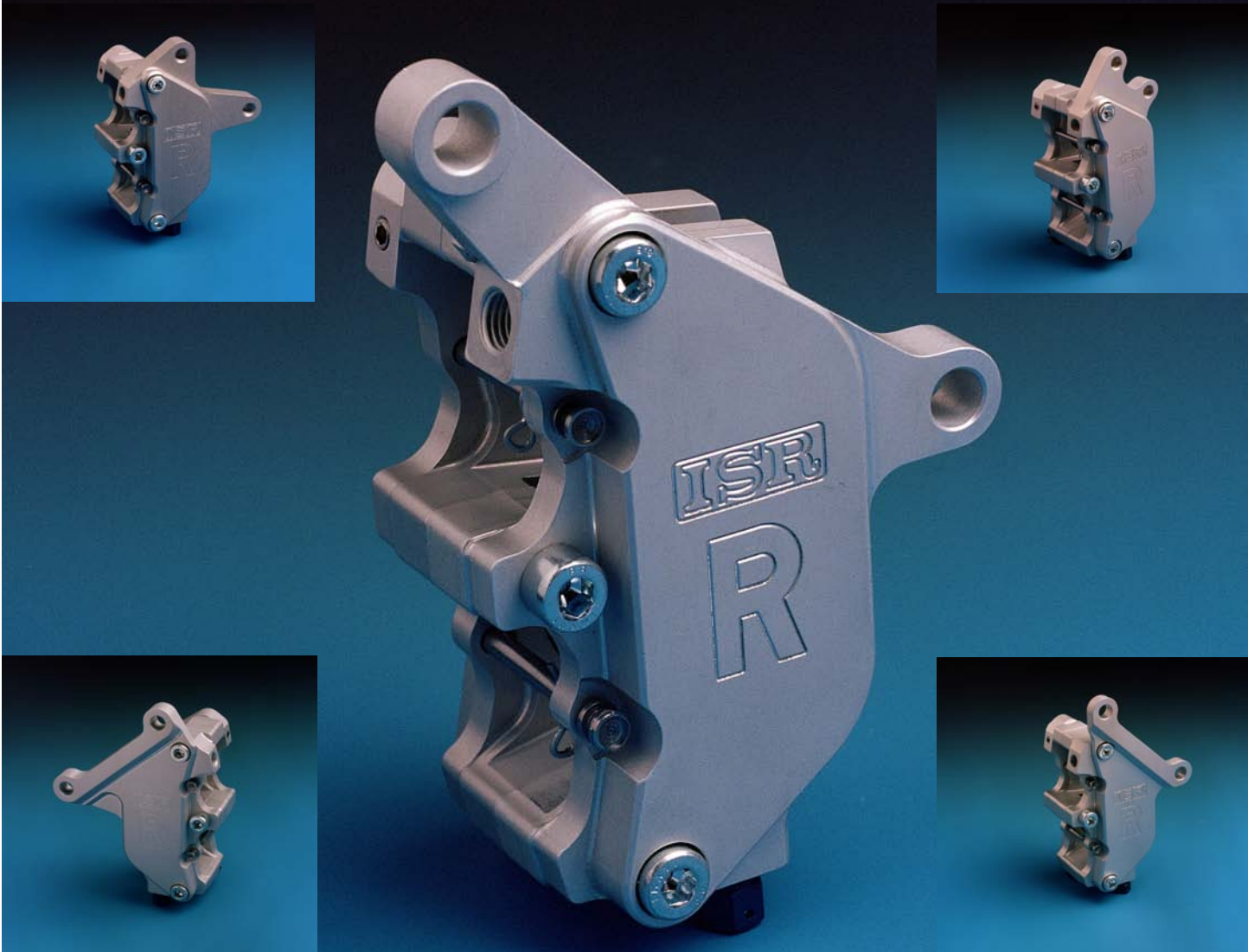

-OR

-OV

This well proven caliper must be one of the most cost effective performance choices available on the market today .

To use it up front represents a sizeable upgrade to the vast majority of street bikes , either singularly or in double form , depending on original installation.

Another application which has proven itself is at the rear of heavier touring and custom bikes as well as on choppers with a marked rear end weight bias.

In single application a 14mm master is recommended and in pairs a 17,5mm master cylinder usually does the job.

# ISR

PART NUMBER : 22-025-OG (RH)  
22-025-OH (LH)

22-025-OG

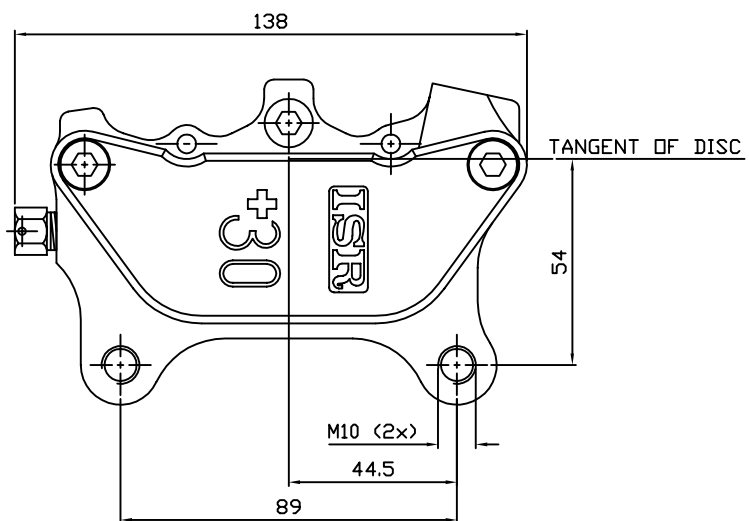
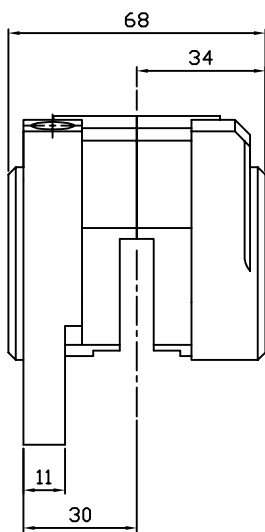

## Technical data:

Piston diameter:	34mm (x4)
Piston material:	Tufram coated aluminium alloy
Pad type:	Ferodo FDB 207 (x4)
Pad area:	25.6cm <sup>2</sup>
Swept height of disc:	35mm
Disc size:	170-330mm
Disc thickness:	4.5-6.0mm
Hydraulic threads:	M10x1.25
Weight incl. pads:	0.91kg
Surface finish:	Clear anodised

# ISR

PART NUMBER : 22-025-OK (RH)  
22-025-OL (LH)

22-025-OK

Brembo 40mm  
boltpattern

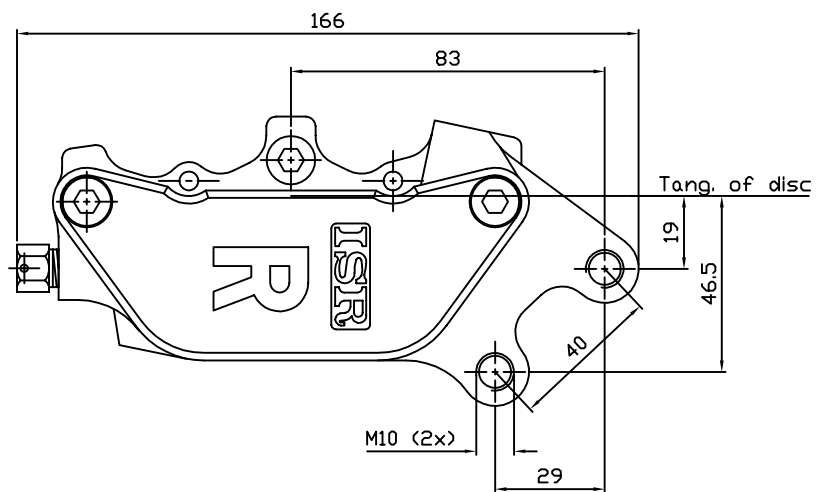
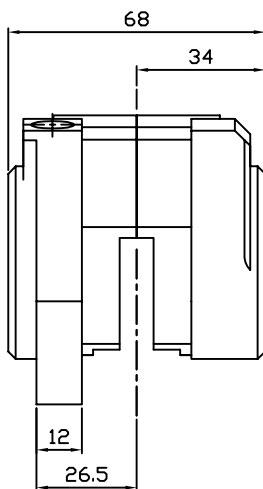

## Technical data:

Piston diameter:	34mm (x4)
Piston material:	Tufram coated aluminium alloy
Pad type:	Ferodo FDB 207 (x4)
Pad area:	25.6cm <sup>2</sup>
Swept height of disc:	35mm
Disc size:	220-330mm
Disc thickness:	4.5-6.0mm
Hydraulic threads:	M10x1.25
Weight incl. pads:	0.89kg
Surface finish:	Clear anodised

# ISR

PART NUMBER : 22-025-OU (RH)  
22-025-OV (LH)

## 22-025-OU (HD-CALIPER)

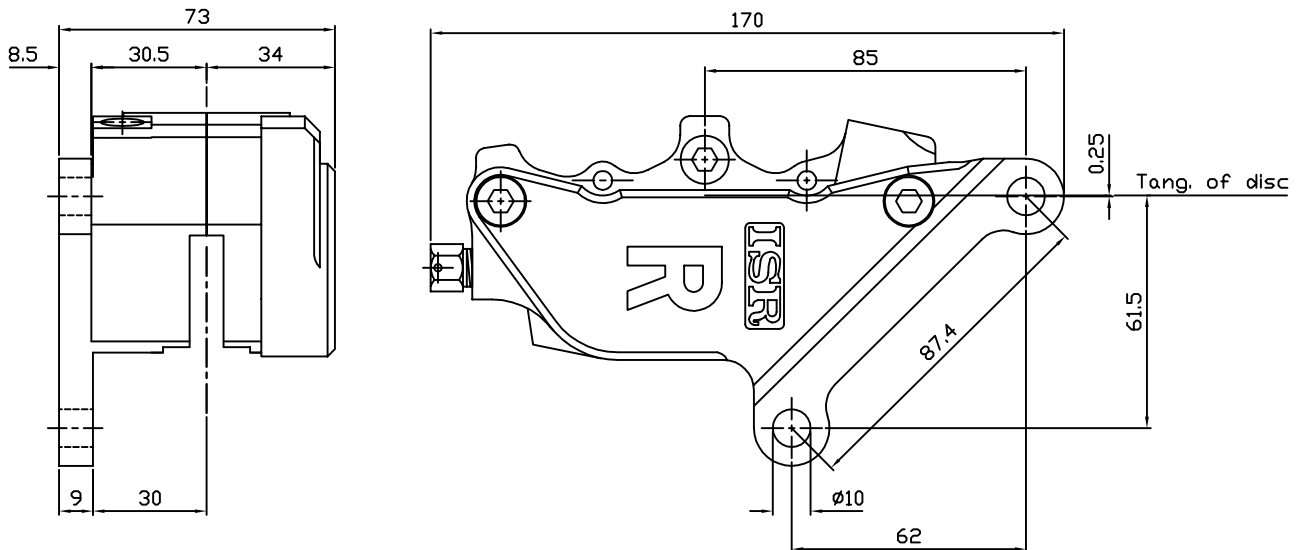

### Technical data:

Piston diameter:	34mm (x4)
Piston material:	Tufram coated aluminium alloy
Pad type:	Ferodo FDB 207 (x4)
Pad area:	25.6cm <sup>2</sup>
Swept height of disc:	35mm
Disc size:	293mm
Disc thickness:	4.5-6.0mm
Hydraulic threads:	M10x1.25
Weight incl. pads:	0.87kg
Surface finish:	Clear anodised

# ISR

PART NUMBER : 22-025-0X (RH)  
22-025-0Y (LH)

22-025-0X (HD-CALIPER)

w. Narrow Fork/Wire

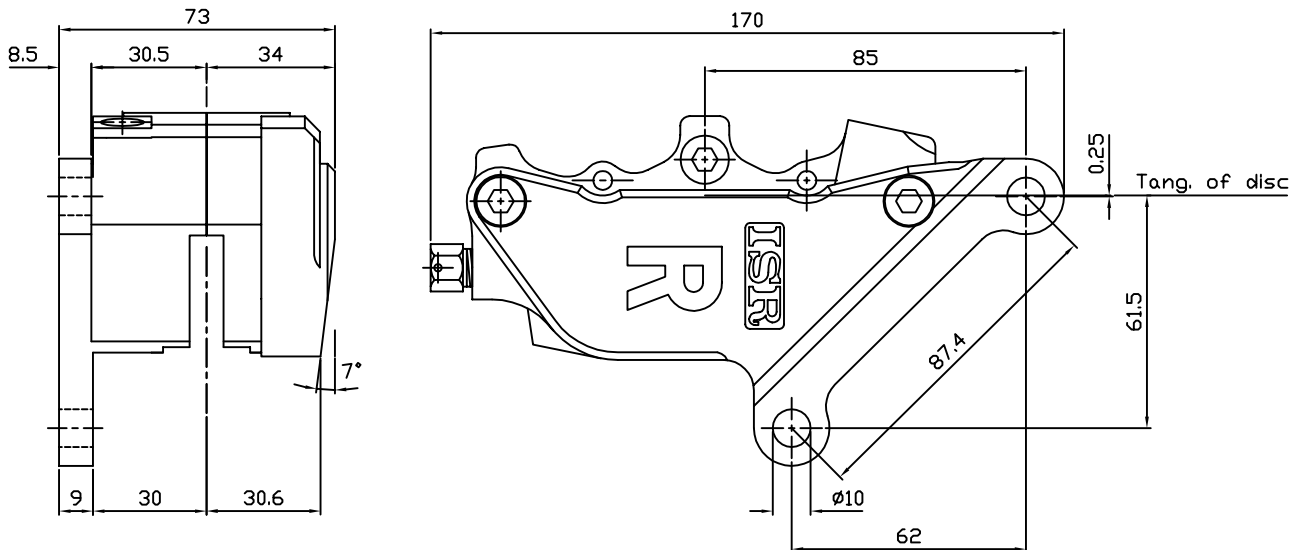

## Technical data:

Piston diameter:	34mm (x4)
Piston material:	Tufram coated aluminium alloy
Pad type:	Ferodo FDB 207 (x4)
Pad area:	25.6cm <sup>2</sup>
Swept height of disc:	35mm
Disc size:	293mm
Disc thickness:	4.5-6.0mm
Hydraulic threads:	M10x1.25
Weight incl. pads:	0.87kg
Surface finish:	Clear anodised



**S**procket caliper for use in the combined sprocket/disc unit which leaves the other side of the wheel free and uncluttered from assorted brake paraphernalia. 21-009 is the recommended master cylinder for this caliper.

# ISR

PART NUMBER : 22-026-0A

22-026-0A

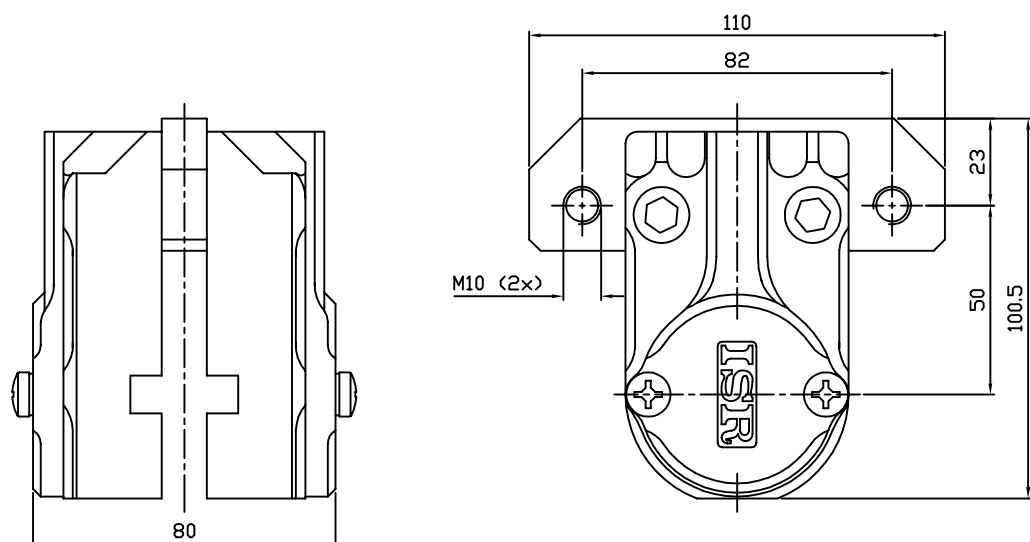

## Technical data:

Piston diameter:	43mm (x2)
Piston material:	Tufam coated aluminium alloy
Pad type:	Ferodo FDB 157 (x2)
Pad area:	18cm <sup>2</sup>
Swept height of disc:	48mm
Disc size:	210mm →
Disc thickness:	Fits 530-sprockets (9mm)
Hydraulic threads:	M10x1.25
Weight incl. pads:	0.87 kg
Surface finish:	Clear anodised



22-027-0A



Versatile caliper intended for rear wheel use, which also has found a variety of other applications both industrial and other . Suitable master cylinders being 21-009 and 21-010.

# ISR

PART NUMBER : 22-027-0A (RH)  
22-027-0B (LH)

22-027-□A

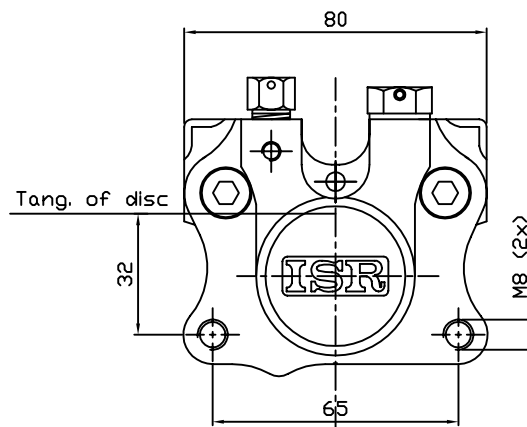
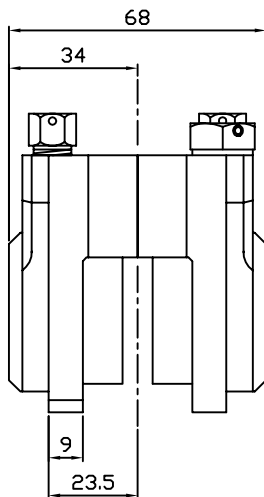

## Technical data:

Piston diameter:	34mm (x2)
Piston material:	Tufram coated aluminium alloy
Pad type:	Ferodo FDB 207 (x2)
Pad area:	12.8cm <sup>2</sup>
Swept height of disc:	35mm
Disc size:	170-280mm
Disc thickness:	4.5-6.0mm
Hydraulic threads:	M10x1.25
Weight incl. pads:	0.53kg
Surface finish:	Clear anodised



# 22-028-0A

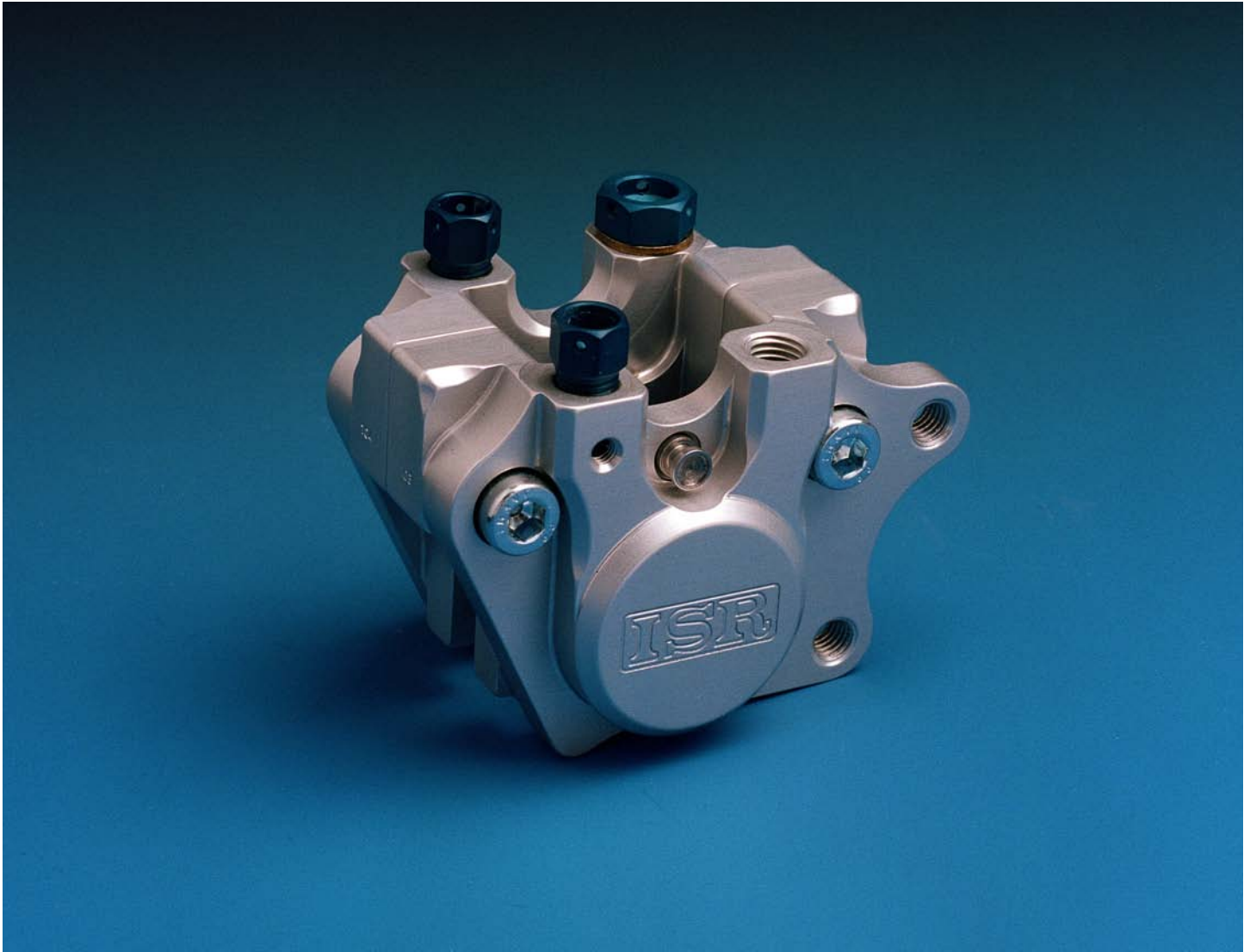

**T**his little versatile caliper has proven to be our top seller , having found its use both on choppers, horse carts and go karts , in most cases with 220mm to 280mm discs .  
Always use a 14mm master cylinder , always use a pair of these at the front of a chopper.

# ISR

PART NUMBER : 22-028-0A (RH)  
22-028-0B (LH)

22-028-0A

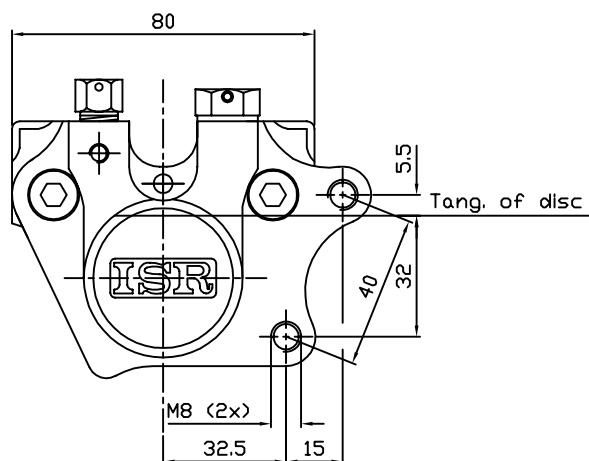
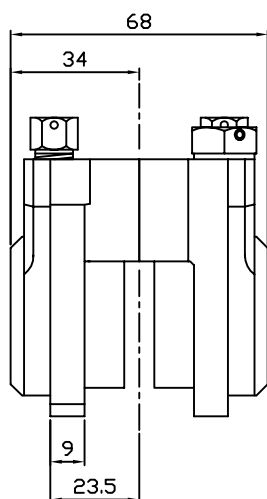

## Technical data:

Piston diameter:	34mm (x2)
Piston material:	Tufram coated aluminium alloy
Pad type:	Ferodo FDB 207 (x2)
Pad area:	12.8cm <sup>2</sup>
Swept height of disc:	35mm
Disc size:	170-280mm
Disc thickness:	4.5-6.0mm
Hydraulic threads:	M10x1.25
Weight incl. pads:	0.53kg
Surface finish:	Clear anodised



# The 22-029 Family

-OC

-OA



-OE

**-OA** ; Lightweight rear caliper , for sports and racing machines , with integral bracket for a 210mm disc. Suitable master cylinder size is 14mm.

**-OC** ; Lightweight rear caliper , for sports and racing machines , with integral bracket for a 250mm disc. Suitable master cylinder size is 14mm.

**-OE** ; Special version of the -029 caliper for non Harley springer front forks , bracket for 250mm disc. 14mm master cylinder is recommended.

# ISR

PART NUMBER : 22-029-0A (RH)  
22-029-0B (LH)

22-029-0A

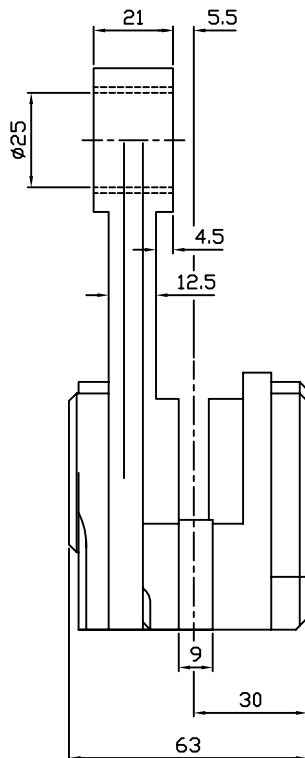

MAX NAVDIAMETER  
PÅ HJUL  $\varnothing 125$

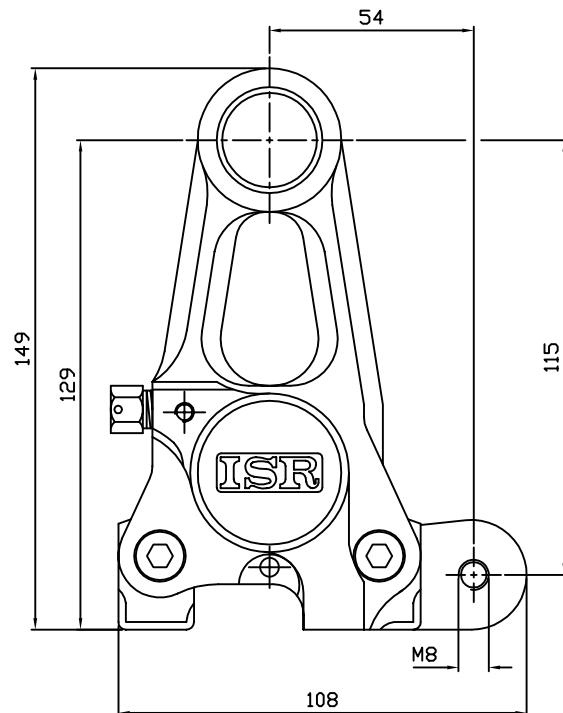

## Technical data:

Piston diameter:	34mm (x2)
Piston material:	Tufram coated aluminium alloy
Pad type:	Ferodo FDB 207 (x2)
Pad area:	12.8cm <sup>2</sup>
Swept height of disc:	35mm
Disc size:	210mm
Disc thickness:	4.5–6.0mm
Hydraulic threads:	M10x1.25
Weight incl. pads:	0.60kg
Surface finish:	Clear anodised

# ISR

PART NUMBER : 22-029-0C (RH)  
22-029-0D (LH)

22-029-0C

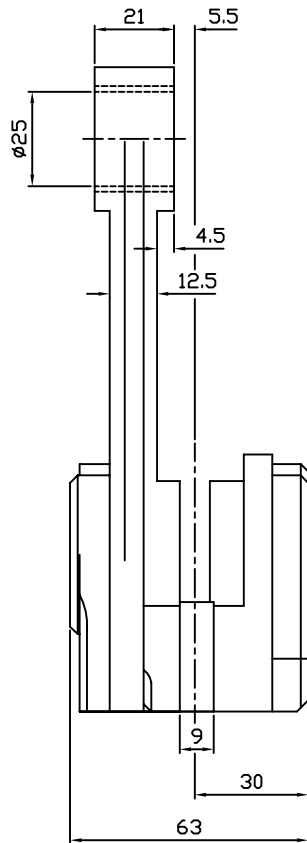

MAX NAVDIAMETER  
PÅ HJUL  $\varnothing 169$

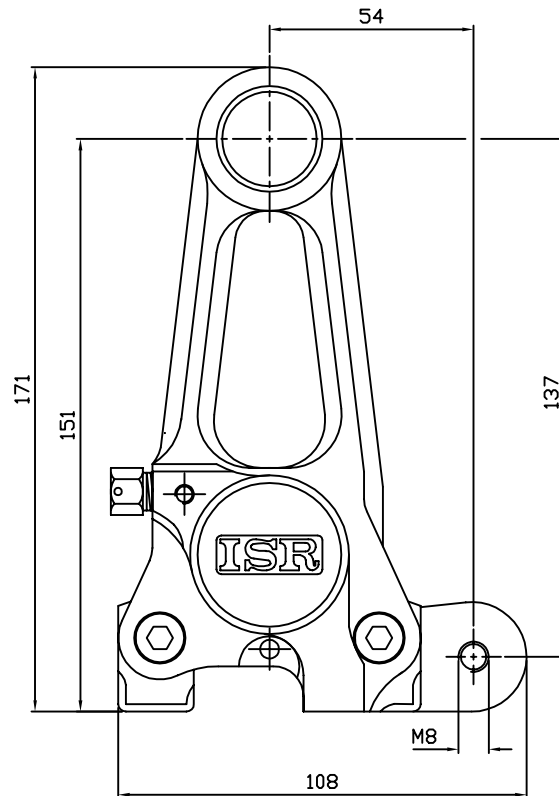

## Technical data:

Piston diameter:	34mm (x2)
Piston material:	Tufram coated aluminium alloy
Pad type:	Ferodo FDB 207 (x2)
Pad area:	12.8cm <sup>2</sup>
Swept height of disc:	35mm
Disc size:	254mm
Disc thickness:	4.5–6.0mm
Hydraulic threads:	M10x1.25
Weight incl. pads:	0.62kg
Surface finish:	Clear anodised

# ISR

PART NUMBER : 22-029-0E (RH)  
22-029-0F (LH)

## 22-029-0E

For non Harley Springer forks

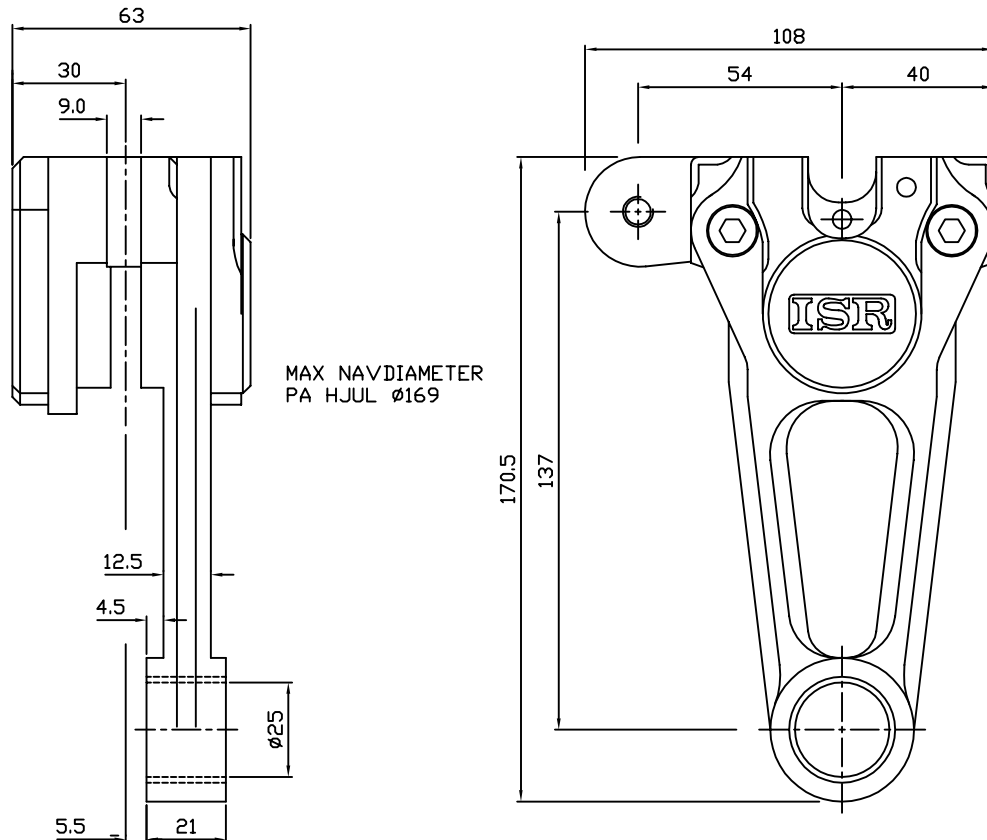

### Technical data:

Piston diameter:	34mm (x2)
Piston material:	Tufram coated aluminium alloy
Pad type:	Ferodo FDB 207 (x2)
Pad area:	12.8cm <sup>2</sup>
Swept height of disc:	35mm
Disc size:	254mm
Disc thickness:	4.5–6.0mm
Hydraulic threads:	M10x1.25
Weight incl. pads:	0.62kg
Surface finish:	Clear anodised



# 22-030-0A

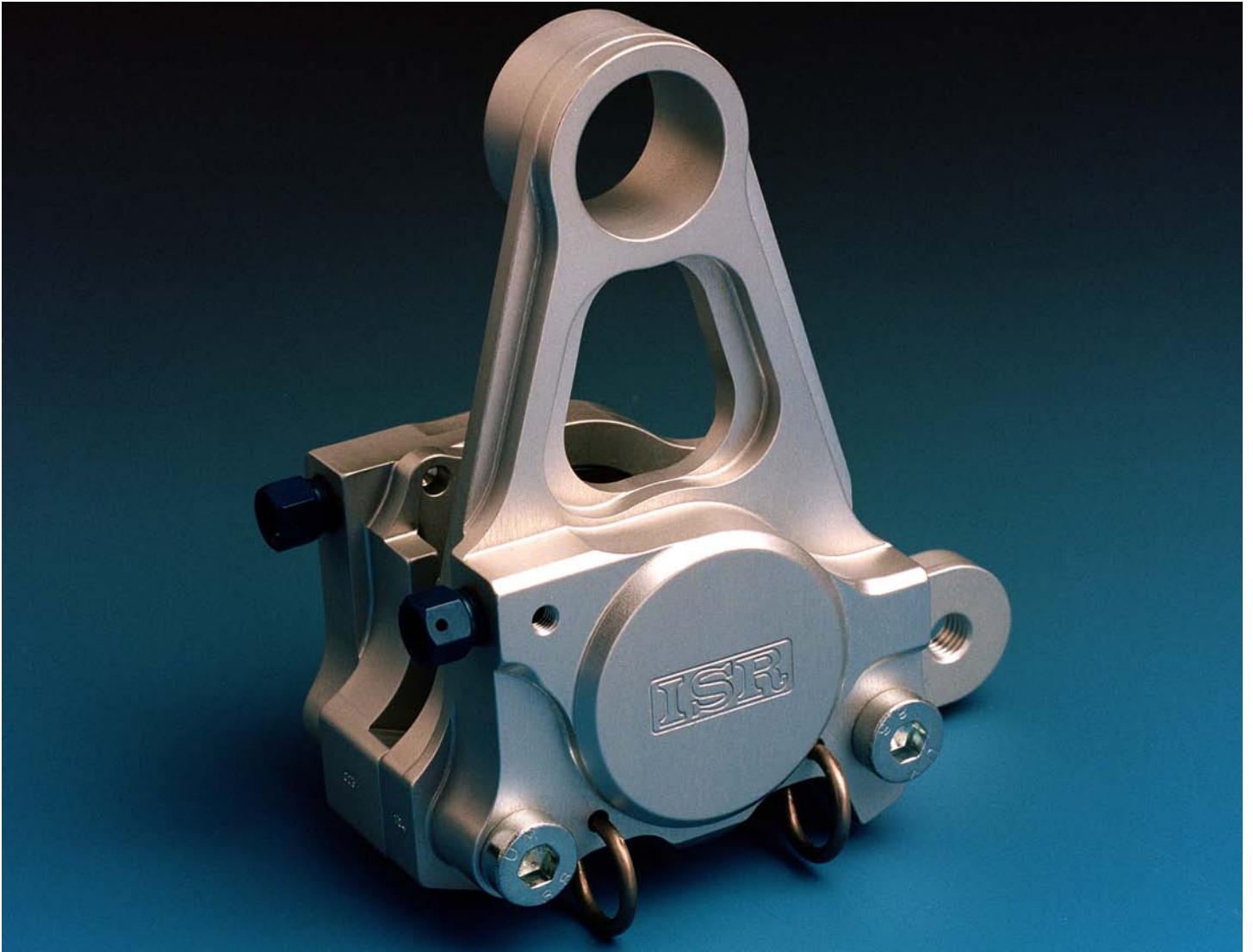

**A** more powerful lightweight rear brake caliper with integral bracket for a 220mm disc .  
Suitable master cylinder bore is 14mm.

# ISR

PART NUMBER : 22-030-0A (RH)  
22-030-0B (LH)

22-030-□A

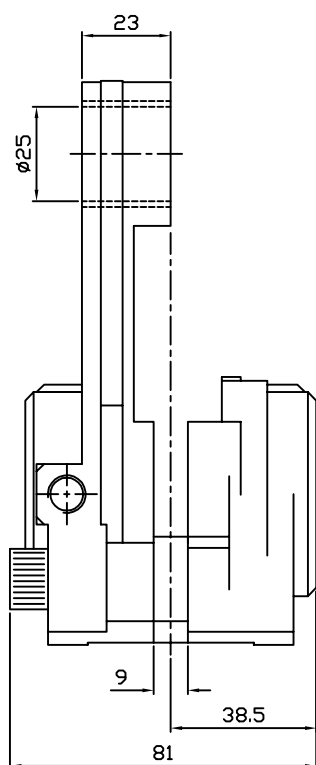

MAX NAVDIAMETER  
PÅ HJUL Ø118

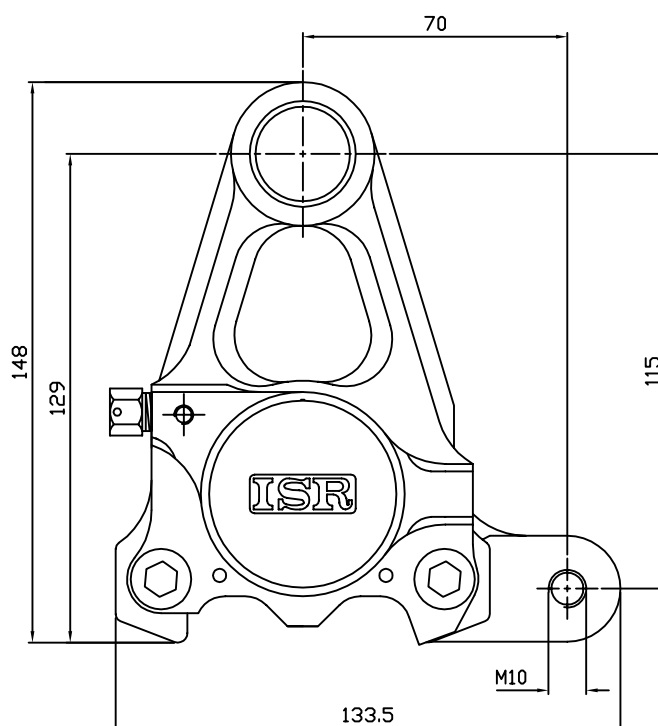

## Technical data:

Piston diameter:	43mm (x2)
Piston material:	Tufram coated aluminium alloy
Pad type:	Ferodo FDB 342 (x2)
Pad area:	22.1cm <sup>2</sup>
Swept height of disc:	43mm
Disc size:	220mm
Disc thickness:	5.0–6.0mm
Hydraulic threads:	M10x1.25
Weight incl. pads:	0.97kg
Surface finish:	Clear anodised



# 22-030-0E

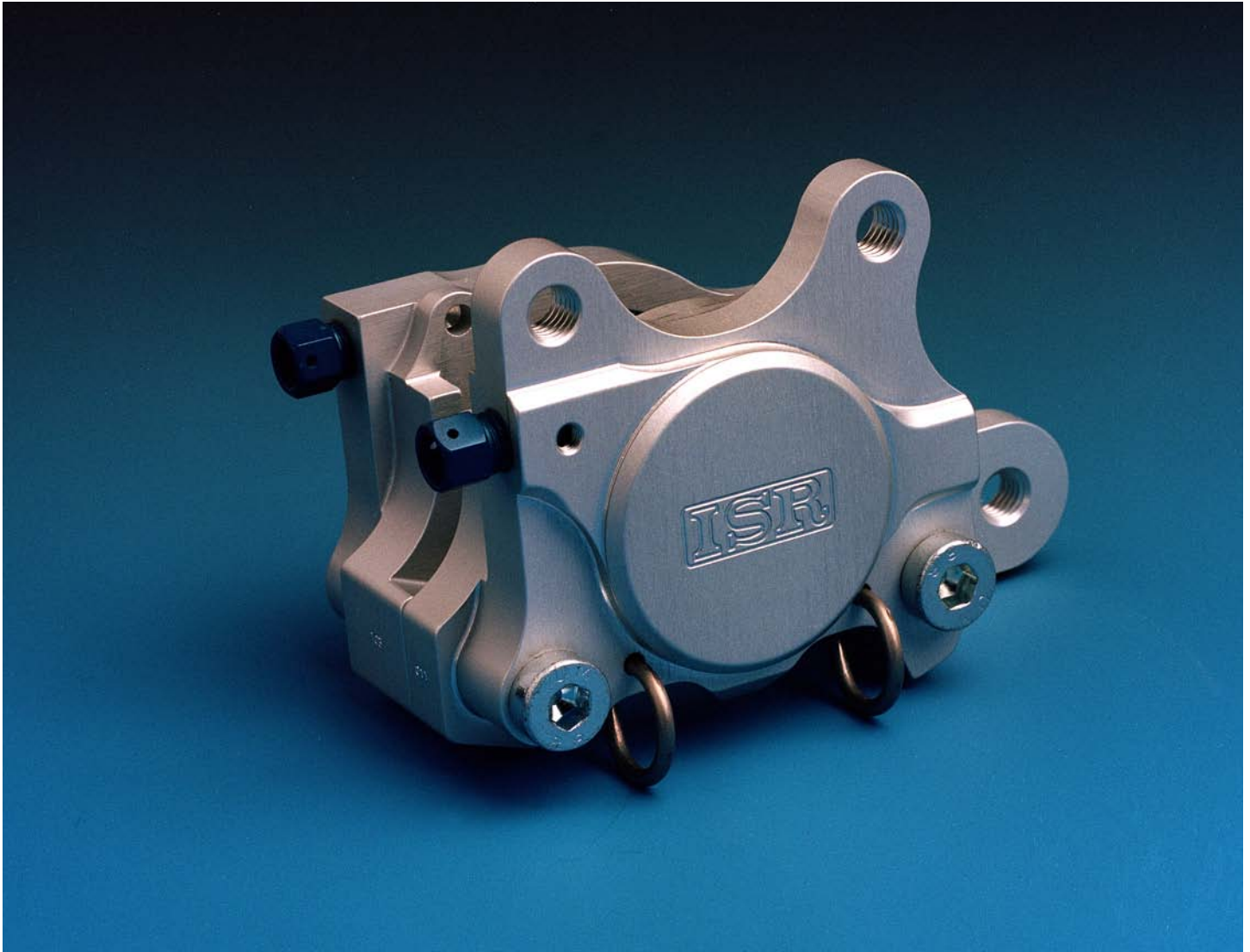

**T**his caliper is intended as a powerful rear brake , it is compatible with any conceivable disc size .  
We can provide an assortment of brackets.

# ISR

PART NUMBER : 22-030-OE (RH)  
22-030-OF (LH)

22-030-OE

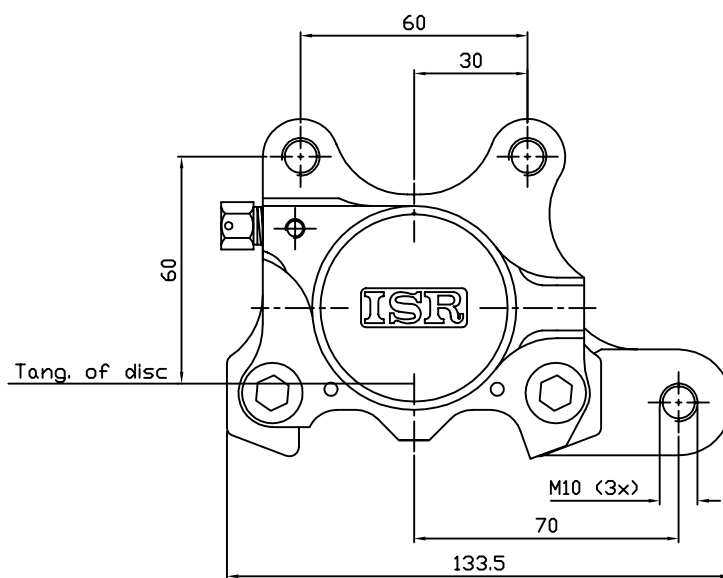
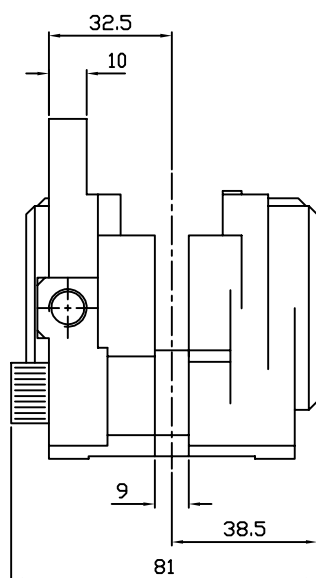

## Technical data:

Piston diameter:	43mm (x2)
Piston material:	Tuftram coated aluminium alloy
Pad type:	Ferodo FDB 342 (x2)
Pad area:	22.1cm <sup>2</sup>
Swept height of disc:	43mm
Disc size:	220-300mm
Disc thickness:	5.0-6.0mm
Hydraulic threads:	M10x1.25
Weight incl. pads:	0.88kg
Surface finish:	Clear anodised



# The 032 Family



-OA

-OG

-OM

-OO

This is the trendsetting original monobloc six piston caliper from back in -89 . Its power to weight ratio has yet to be bettered.

The main advantage of this six piston caliper is that it allows for a greater effective radius of the friction area for a given piston area. The larger effective radius of the disc results in a lighter and more even distribution of heat over the disc surface , thus minimizing the warp risk of said disc.

The caliper is designed with six separate pockets , each with its own pad , thus rendering them firmly in situ , even though the pads locking pin should fall out , all in the name of safety.

A variety of applications of this caliper have proven possible , two up front on bigger bikes and single on 125:s and drag bikes , as well as in the rear of both drag and custom bikes.

Suitable master cylinder sizes are 17,5 mm for double use , and 14mm for single use.

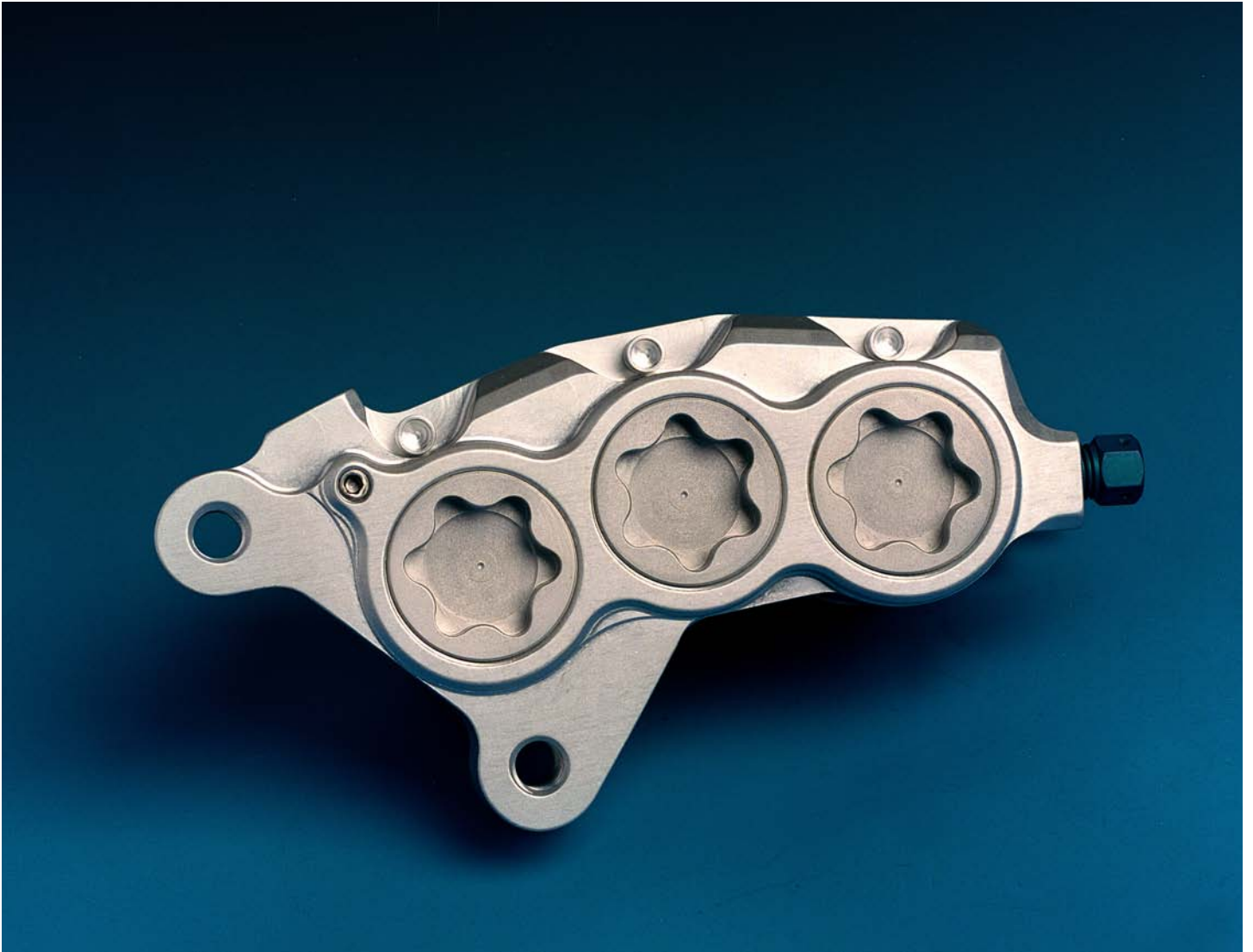

**T**his is an improved version of the trendsetting original monobloc six piston caliper from back in -89 . Whose power to weight ratio has yet to be bettered.

The main advantage of this six piston caliper is that it allows for a greater effective radius of the friction area for a given piston area. The larger effective radius of the disc results in a lighter and more even distribution of heat over the disc surface , thus minimizing the warp risk of said disc.

The caliper is designed with six separate pockets , each with its own pad , thus rendering them firmly in situ , even though the pads locking pin should fall out , all in the name of safety.

A variety of applications of this caliper have proven possible , two up front on bigger bikes and single on 125:s and drag bikes , as well as in the rear of both drag and custom bikes.

Suitable master cylinder sizes are 17,5 mm for double use , and 14mm for single use.

# ISR

PART NUMBER : 22-032-AC (RH)  
22-032-AD (LH)

22-032-AC HD -00 →  
FITS STANDARD DISCSIZE

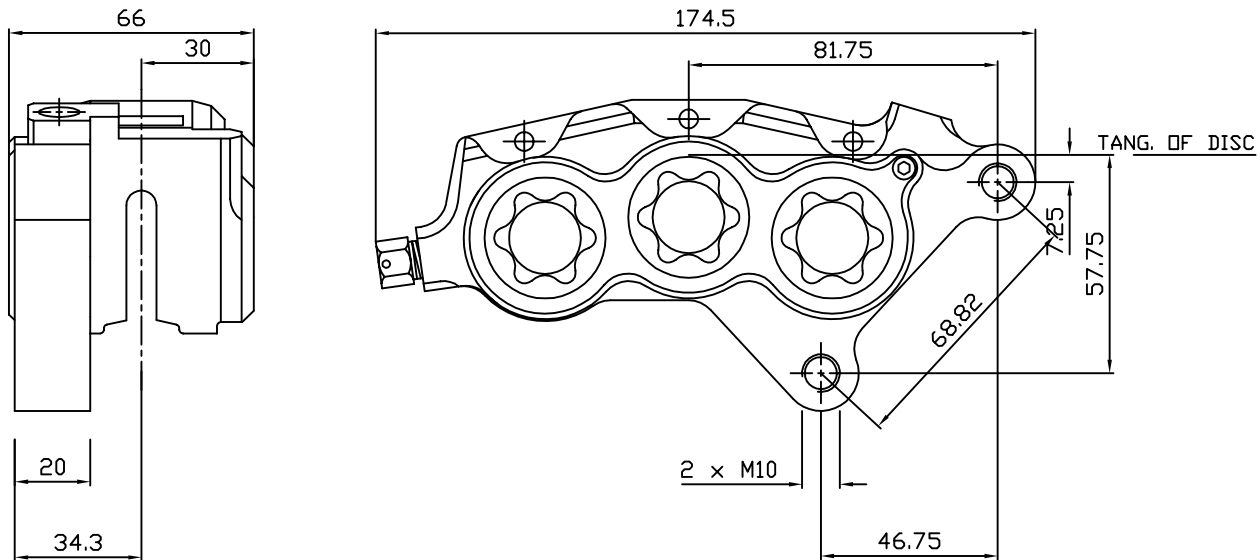

## Technical data:

Piston diameter:	30mm (x6)
Piston material:	Tufram coated aluminium alloy
Pad type:	ISR 29-001 (x6)
Pad area:	31.8cm <sup>2</sup>
Swept height of disc:	33mm
Disc size:	292 mm
Disc thickness:	4.6-5.0mm
Hydraulic threads:	M10x1.25
Weight incl. pads:	0.96kg
Surface finish:	Clear anodised
Included:	2 Bolts M10x40 Banjo bolt and washers

# ISR

PART NUMBER : 22-032-AE (RH)  
22-032-AF (LH)

22-032-AE (YZF R1)

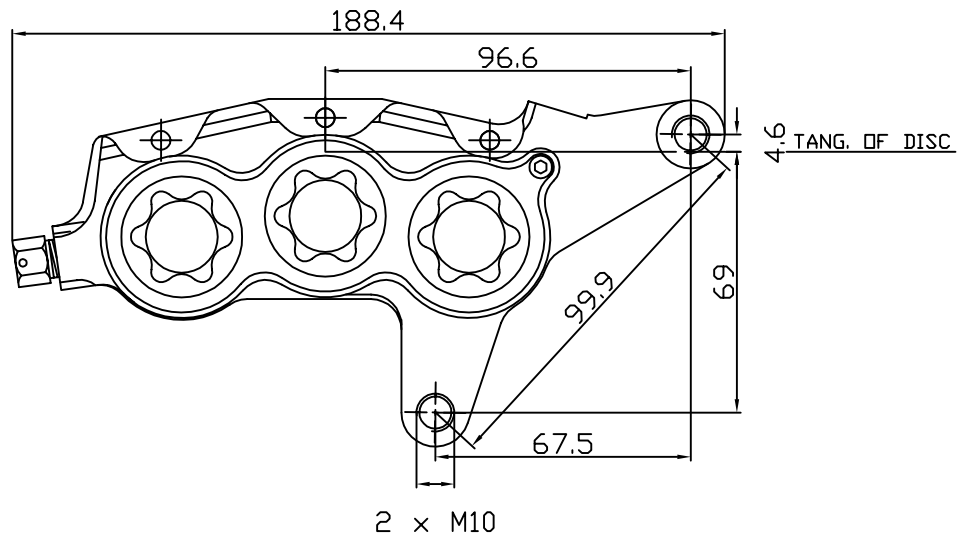
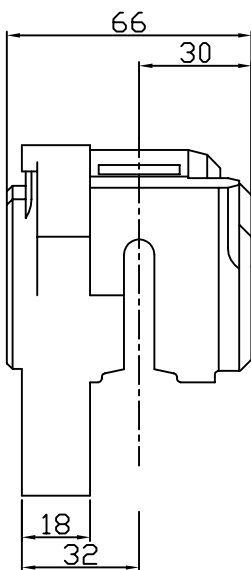

## Technical data:

Piston diameter:	30mm (x6)
Piston material:	Tufram coated aluminium alloy
Pad type:	ISR 29-001 (x6)
Pad area:	31.8cm <sup>2</sup>
Swept height of disc:	33mm
Disc size:	320mm
Disc thickness:	4.6-5.0mm
Hydraulic threads:	M10x1.25
Weight incl. pads:	0.83kg
Surface finish:	Clear anodised

# ISR

PART NUMBER : 22-032-0A (RH)  
22-032-0B (LH)

22-032-0A

Brembo 40mm boltpattern

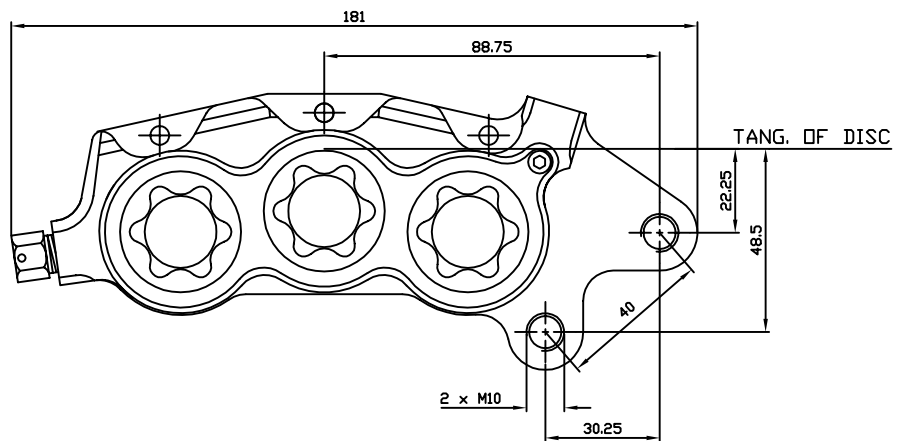
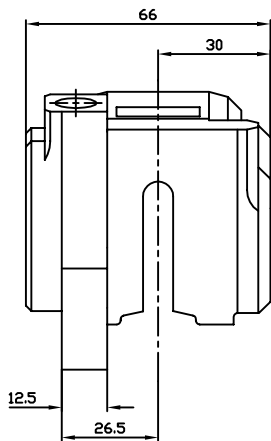

## Technical data:

Piston diameter:	30mm (x6)
Piston material:	Tufram coated aluminium alloy
Pad type:	ISR 29-001 (x6)
Pad area:	31.8cm <sup>2</sup>
Swept height of disc:	33mm
Disc size:	300-320mm
Disc thickness:	4.6-5.0mm
Hydraulic threads:	M10x1.25
Weight incl. pads:	0.82kg
Surface finish:	Clear anodised



# ISR

PART NUMBER : 22-032-OG (RH)  
22-032-OH (LH)

22-032-OG (FZR)

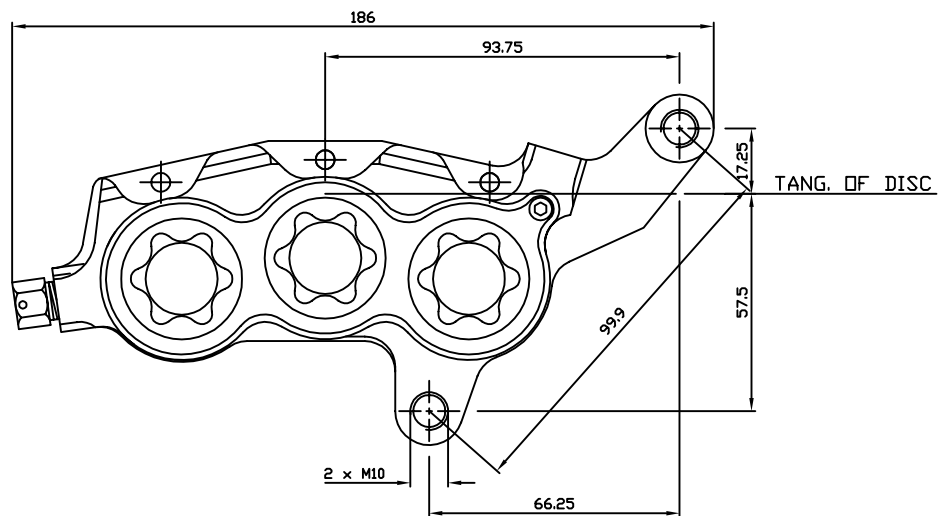
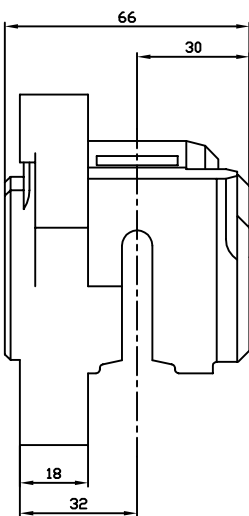

## Technical data:

Piston diameter:	30mm (x6)
Piston material:	Tufram coated aluminium alloy
Pad type:	ISR 29-001 (x6)
Pad area:	31.8cm <sup>2</sup>
Swept height of disc:	33mm
Disc size:	320mm
Disc thickness:	4.6-5.0mm
Hydraulic threads:	M10x1.25
Weight incl. pads:	0.83kg
Surface finish:	Clear anodised

# ISR

PART NUMBER : 22-032-OK (RH)  
22-032-OL (LH)

22-032-OK (ZXR)

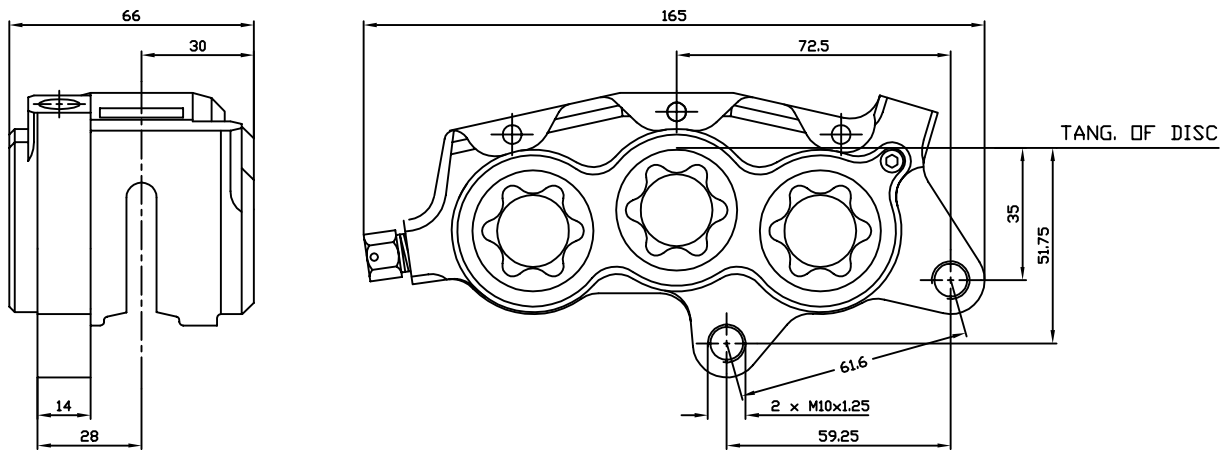

## Technical data:

Piston diameter:	30mm (x6)
Piston material:	Tufram coated aluminium alloy
Pad type:	ISR 29-001 (x6)
Pad area:	31.8cm <sup>2</sup>
Swept height of disc:	33mm
Disc size:	320mm
Disc thickness:	4.6-5.0mm
Hydraulic threads:	M10x1.25
Weight incl. pads:	0.81kg
Surface finish:	Clear anodised

# ISR

PART NUMBER : 22-032-OM (RH)  
22-032-ON (LH)

22-032-□M

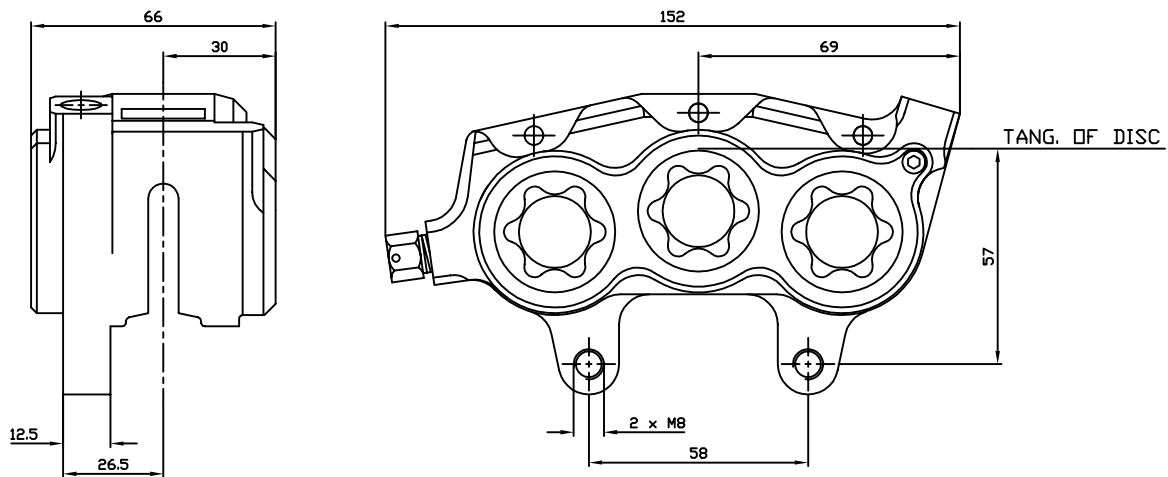

## Technical data:

Piston diameter:	30mm (x6)
Piston material:	Tufram coated aluminium alloy
Pad type:	ISR 29-001 (x6)
Pad area:	31.8cm <sup>2</sup>
Swept height of disc:	33mm
Disc size:	300-320mm
Disc thickness:	4.6-5.0mm
Hydraulic threads:	M10x1.25
Weight incl. pads:	0.80kg
Surface finish:	Clear anodised

# ISR

PART NUMBER : 22-032-00 (RH)  
22-032-0P (LH)

22-032-00 (CBR 900)

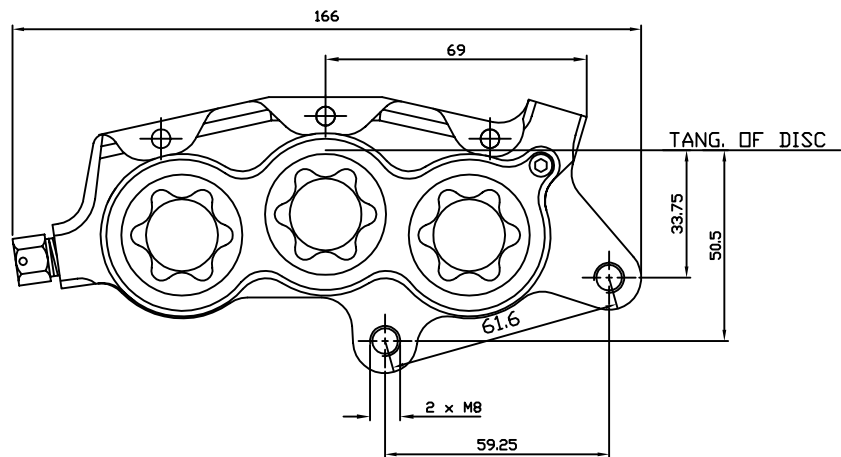
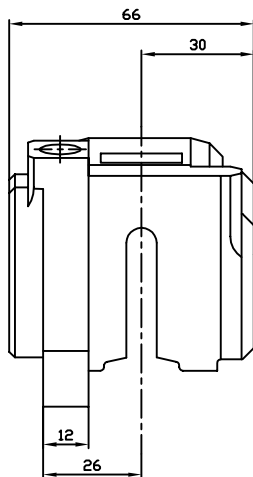

## Technical data:

Piston diameter:	30mm (x6)
Piston material:	Tufram coated aluminium alloy
Pad type:	ISR 29-001 (x6)
Pad area:	31.8cm <sup>2</sup>
Swept height of disc:	33mm
Disc size:	296mm
Disc thickness:	4.6-5.0mm
Hydraulic threads:	M10x1.25
Weight incl. pads:	0.80kg
Surface finish:	Clear anodised

# ISR

PART NUMBER : 22-032-OS (RH)  
22-032-OT (LH)

22-032-OS (CBR 900 Ø320)

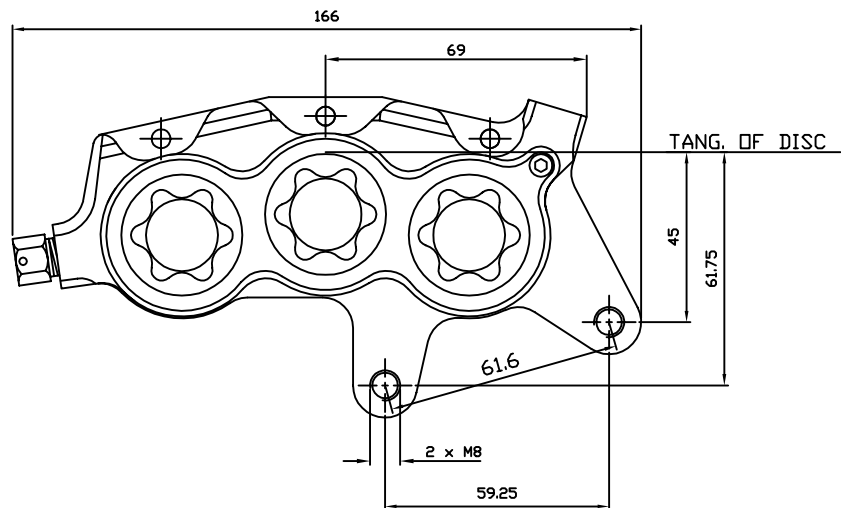
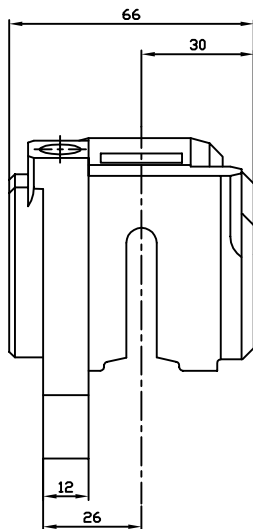

## Technical data:

Piston diameter:	30mm (x6)
Piston material:	Tufram coated aluminium alloy
Pad type:	ISR 29-001 (x6)
Pad area:	31.8cm <sup>2</sup>
Swept height of disc:	33mm
Disc size:	320mm
Disc thickness:	4.6-5.0mm
Hydraulic threads:	M10x1.25
Weight incl. pads:	0.90kg
Surface finish:	Clear anodised



# 22-033-00

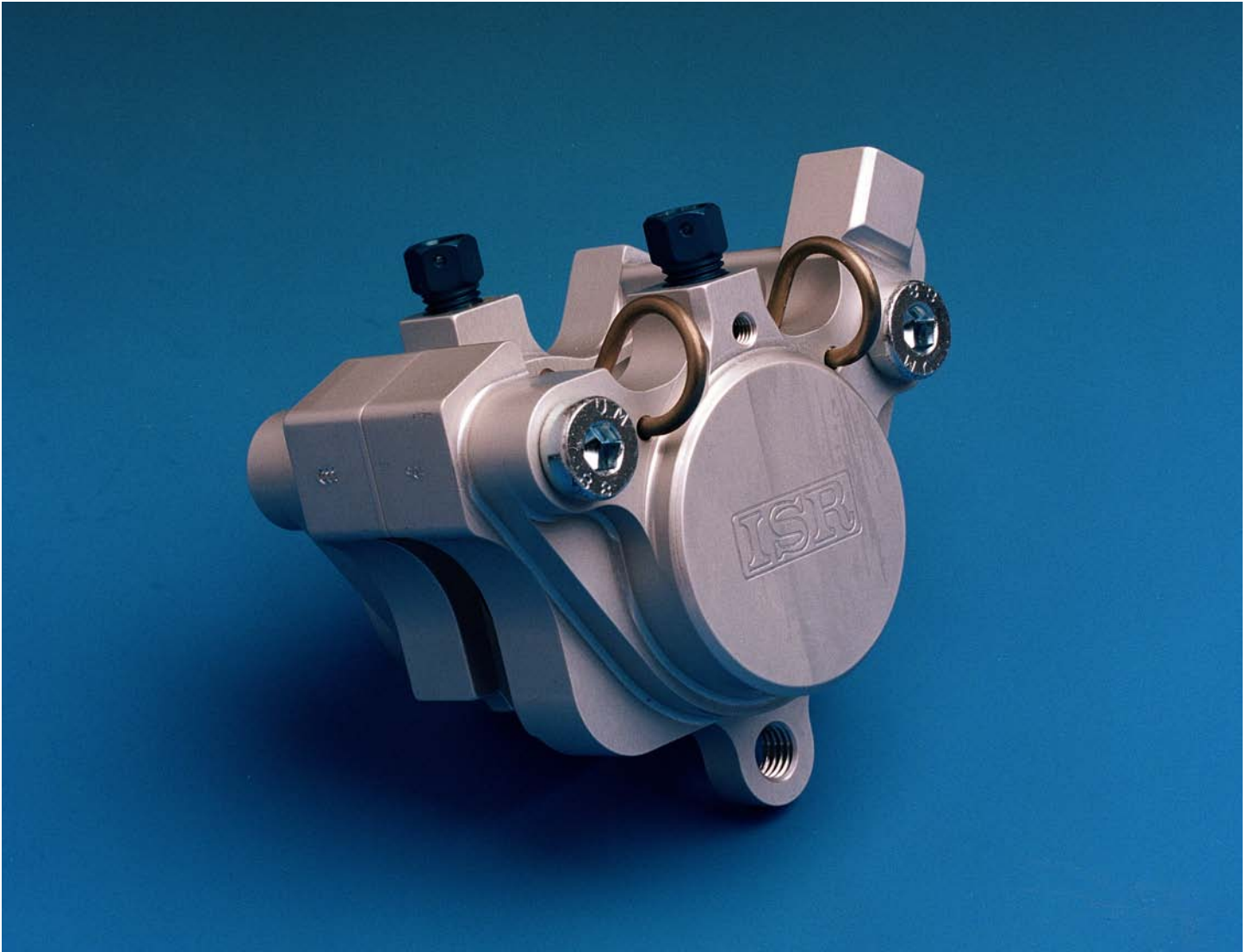

**T**his caliper is a bolt on replacement caliper for wide glide evo Harleys . The standard Harley 292mm discs can be used , but better still , our own discs to further enhance braking performance.

# ISR

# 22-033-0E

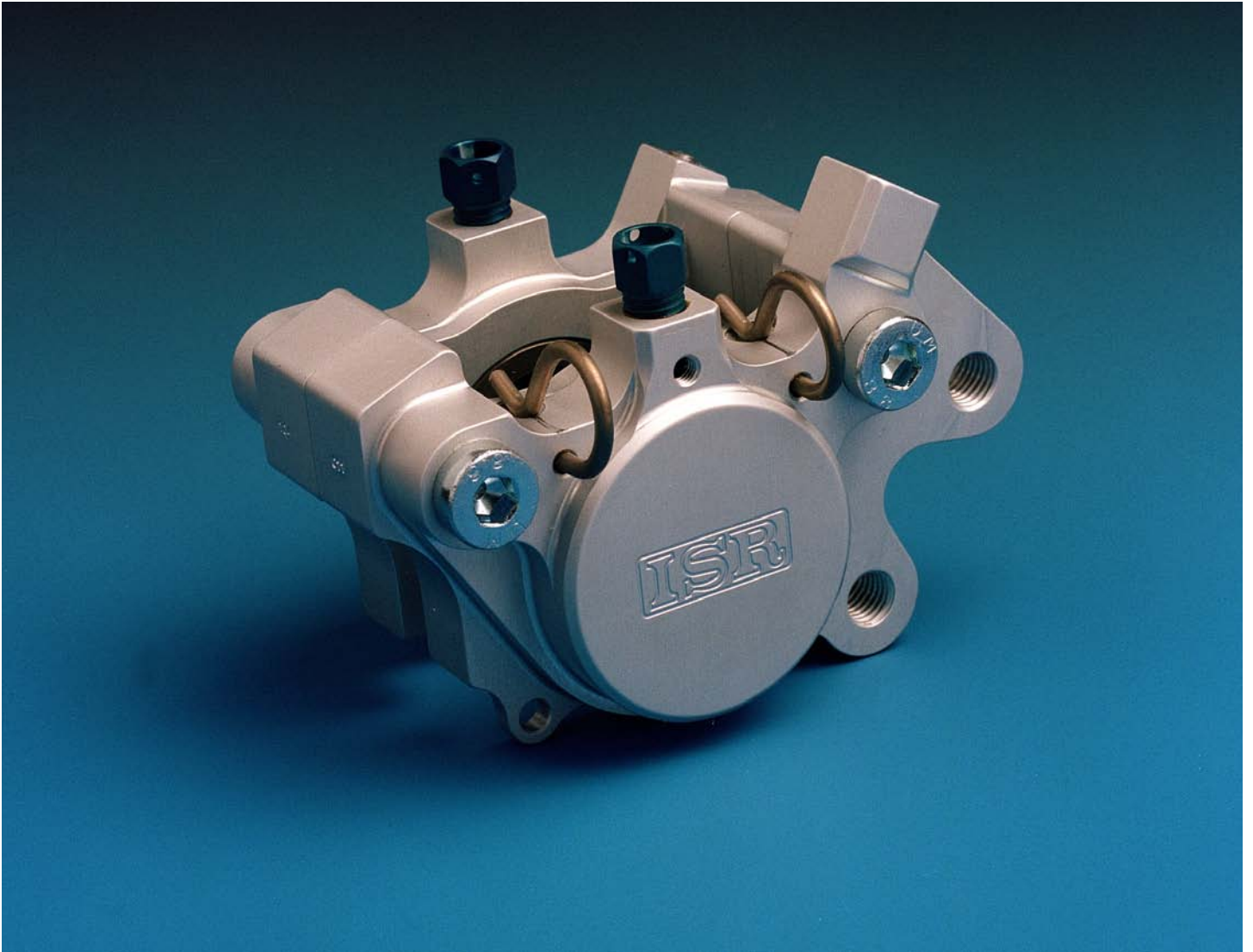

**T**his powerful and cost effective caliper can be used both front and rear on any hog .

In single use a 14mm master cylinder seems to be the way to go , whereas in a double setup the 17,5mm master is more appropriate .



# ISR

PART NUMBER : 22-033-OE (RH)  
22-033-OF (LH)

22-033-□E

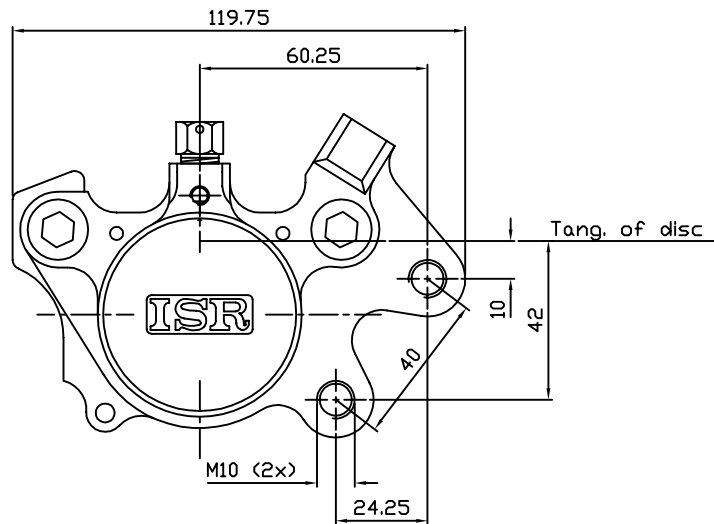
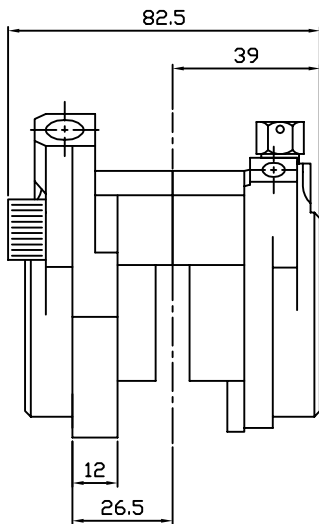

## Technical data:

Piston diameter:	43mm (x2)
Piston material:	Tufam coated aluminium alloy
Pad type:	Ferodo FDB 342 (x2)
Pad area:	22.1cm <sup>2</sup>
Swept height of disc:	43mm
Disc size:	220-300mm
Disc thickness:	5.0-6.0mm
Hydraulic threads:	M10x1.25
Weight incl. pads:	0.86kg
Surface finish:	Clear anodised

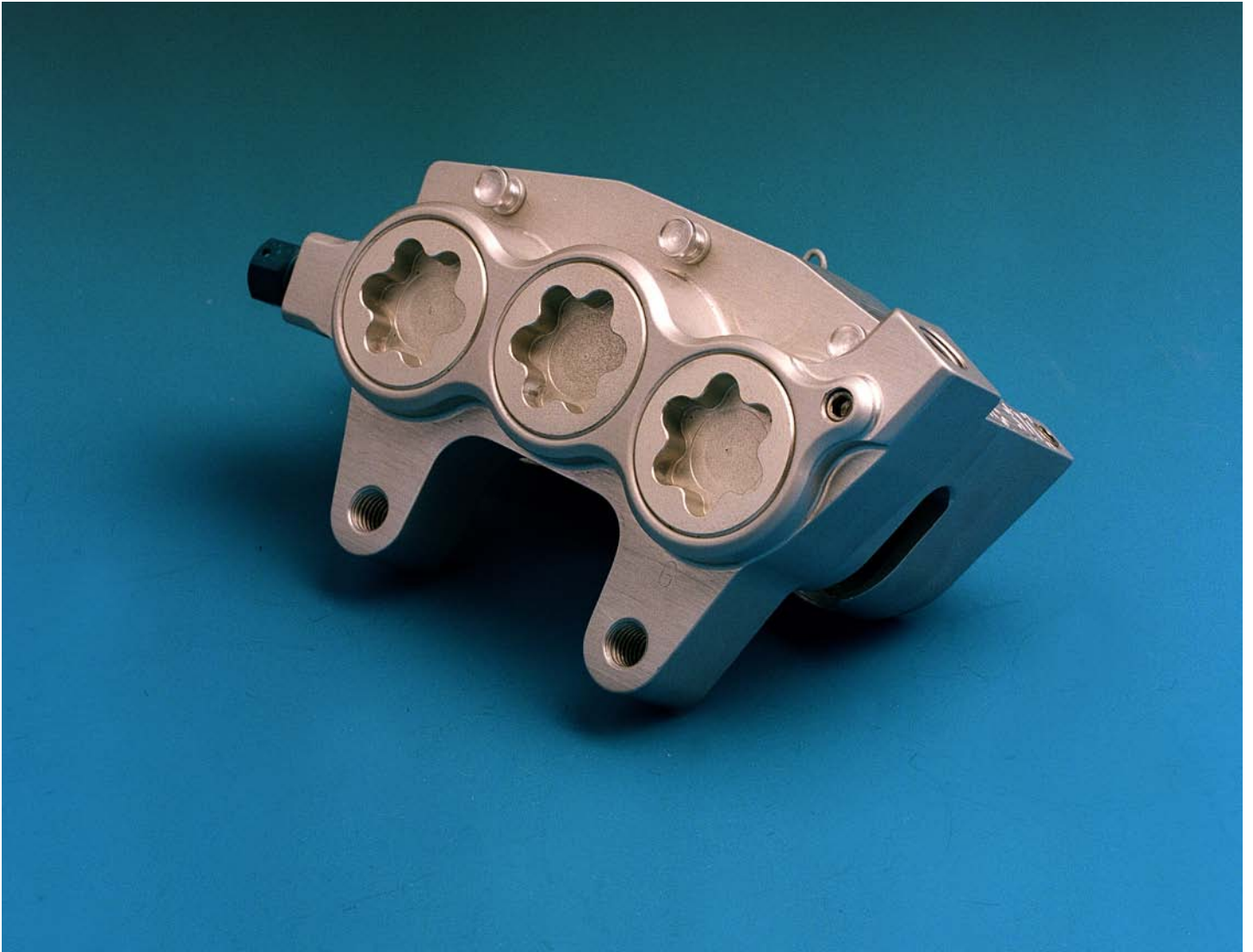

**T**his little six piston caliper in its OC/OD form is directed at the 250cc road racing market. It is intended to be used in twin setup form .

The shown caliper (OG/OH) can be used both front and rear , and has proven popular in drag racing circles at the rear of larger bikes.

The weight of this caliper is an amazing 580 gr , including pads , added to this is the consequent need of the low friction height of only 27mm which renders you very light discs.

When Peter Lindén used this setup on his RS250 GP racer the weight reduction was just under 2kg:s , and that gentlemen, is all unsprung weight.....

# ISR

PART NUMBER : 22-034-0C (RH)  
22-034-0D (LH)

## 22-034-0C

Brembo 40mm boltpattern

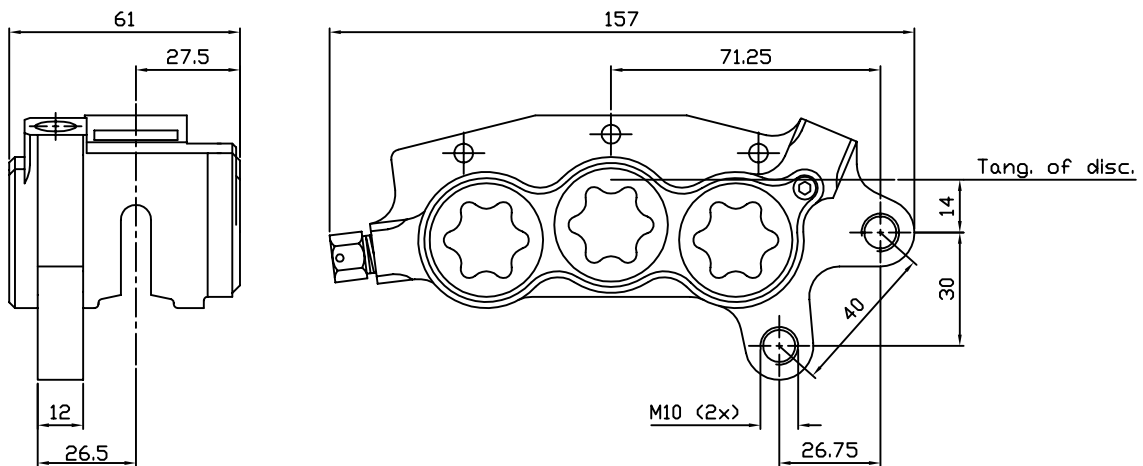

### Technical data:

Piston diameter:	25mm (x6)
Piston material:	Tufram coated aluminium alloy
Pad type:	ISR 29-002 (x6)
Pad area:	20.9cm <sup>2</sup>
Swept height of disc:	27mm
Disc size:	280-300mm
Disc thickness:	4.6-5.0mm
Hydraulic threads:	M10x1.25
Weight incl. pads:	0.58kg
Surface finish:	Clear anodised

# ISR

PART NUMBER : 22-034-OG (RH)  
22-034-OH (LH)

22-034-OG

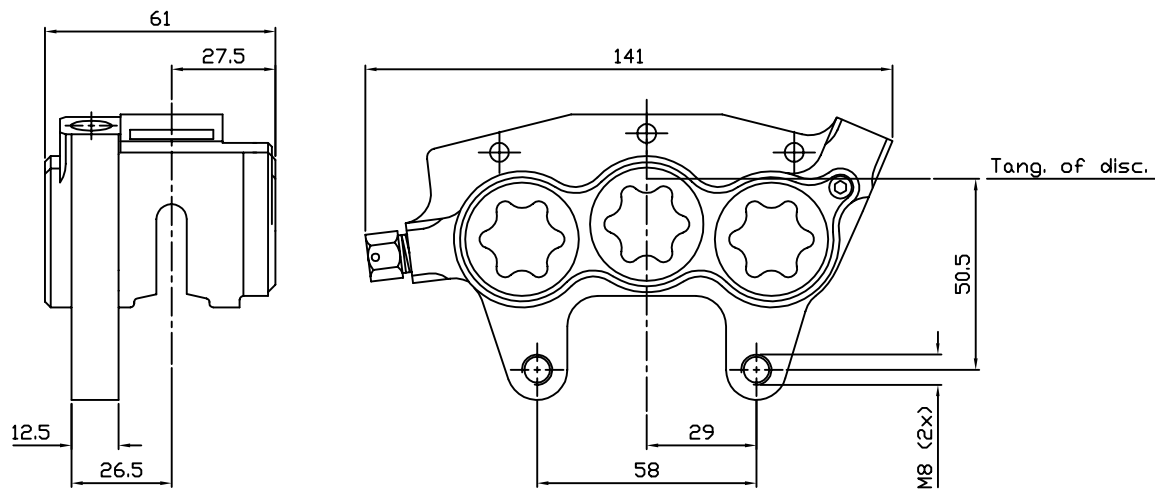

## Technical data:

Piston diameter:	25mm (x6)
Piston material:	Tufram coated aluminium alloy
Pad type:	ISR 29-002 (x6)
Pad area:	20.9cm <sup>2</sup>
Swept height of disc:	27mm
Disc size:	280-300mm
Disc thickness:	4.6-5.0mm
Hydraulic threads:	M10x1.25
Weight incl. pads:	0.58kg
Surface finish:	Clear anodised

# ISR

PART NUMBER : 22-034-OK (RH)  
22-034-OL (LH)

22-034-OL

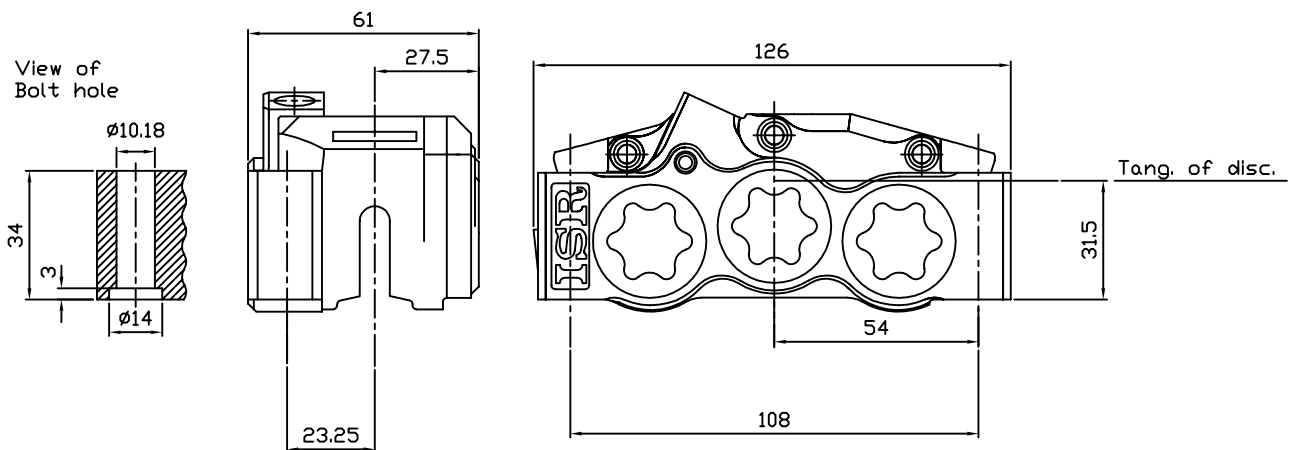

## Technical data:

Piston diameter:	25mm (x6)
Piston material:	Tufram coated aluminium alloy
Pad type:	ISR 29-002 (x6)
Pad area:	20.9cm <sup>2</sup>
Swept height of disc:	27mm
Disc size:	280-300mm
Disc thickness:	4.6-5.0mm
Hydraulic threads:	M10x1.25
Weight incl. pads:	0.58kg
Surface finish:	Clear anodised

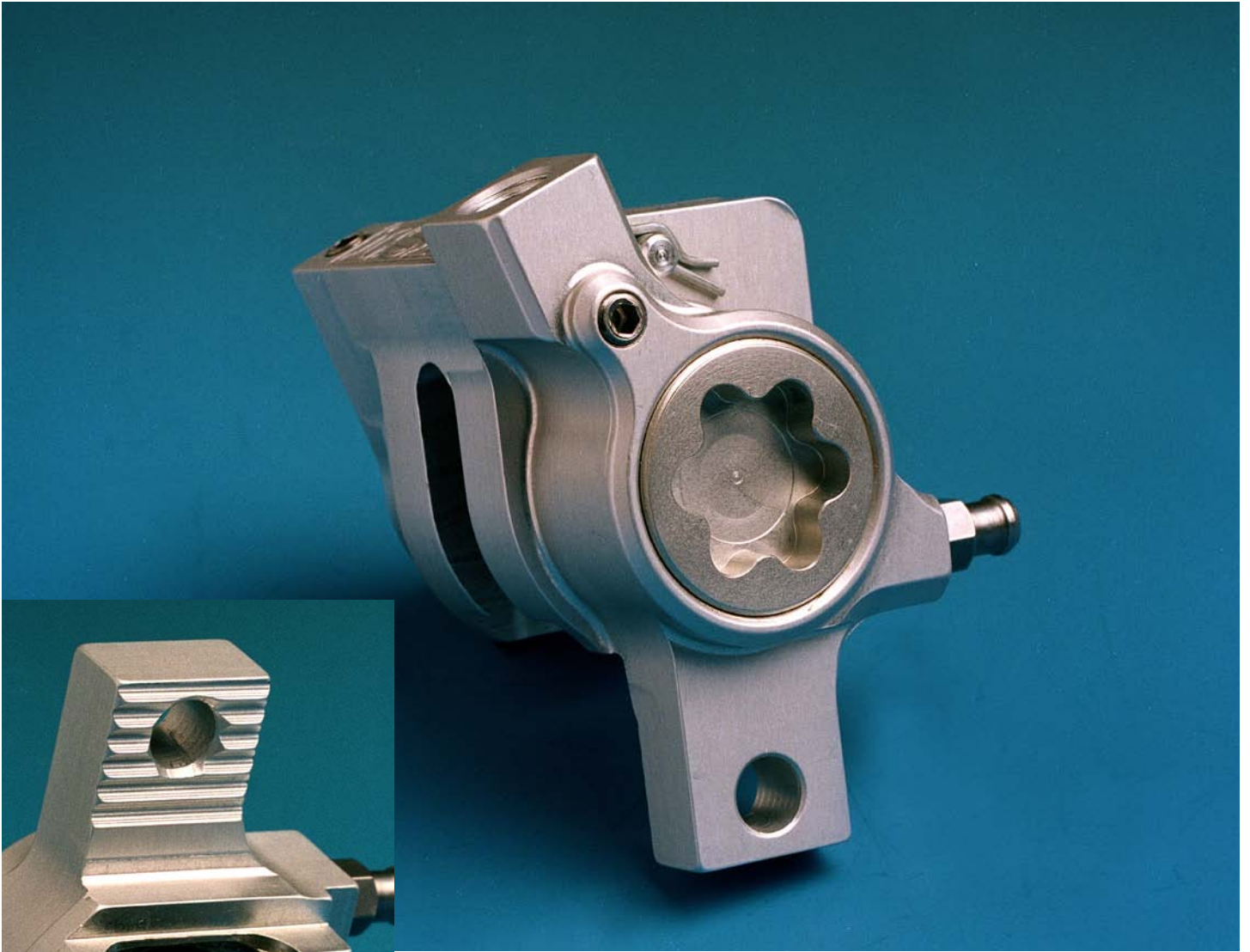

**T**his little caliper was designed with only one goal in mind ; low weight. With only 27mm swept height so the corresponding disc weight is minimal too.

However to chose this setup being a heavy rear wheel breaker borders to blatantly unwise. The one bolt fastening system relies heavily on the v-grooves shown in inserted picture.

# ISR

PART NUMBER : 22-036-0A (RH)  
22-036-0B (LH)

22-036-□A

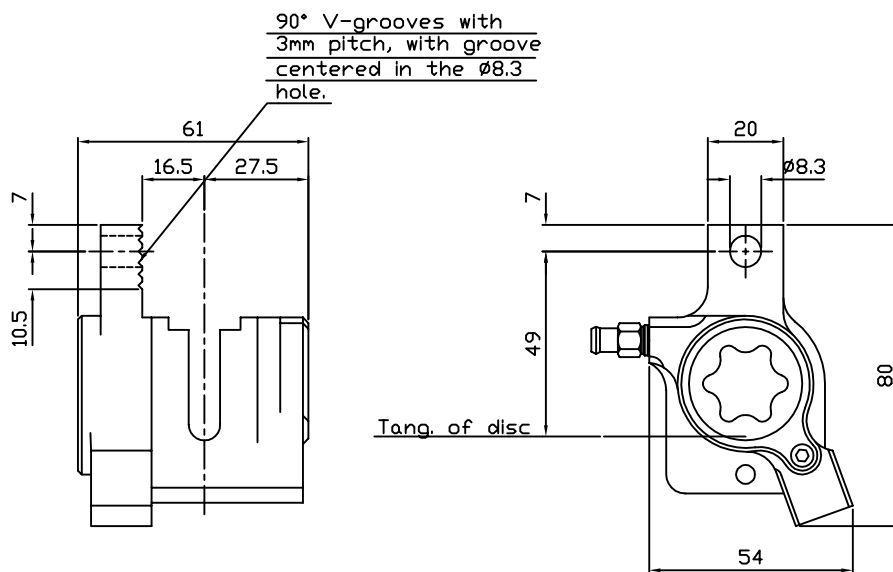

## Technical data:

Piston diameter:	25mm (x2)
Piston material:	Tufram coated aluminium alloy
Pad type:	ISR 29-002 (x2)
Pad area:	7cm <sup>2</sup>
Swept height of disc:	27mm
Disc size:	100-300mm
Disc thickness:	4.6-5.0mm
Hydraulic threads:	M10x1.25
Weight incl. pads:	0.23kg
Surface finish:	Clear anodised



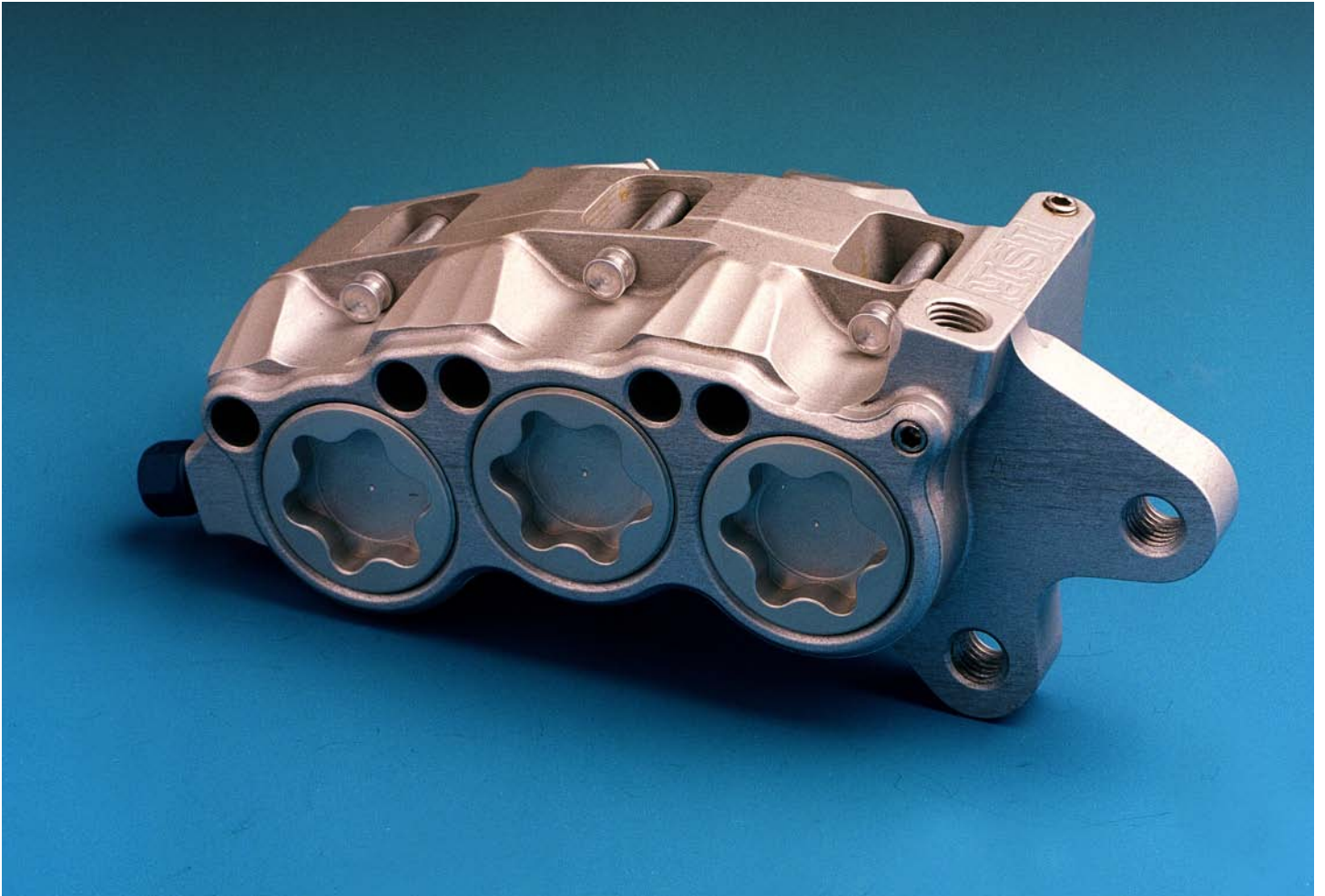

**T**his is the vastly improved version of the original monobloc six piston caliper.

It has stiffeners as well as much improved cooling.

The main advantage of this six piston caliper is that it allows for a greater effective radius of the friction area for a given piston area. The larger effective radius of the disc results in a lighter and more even distribution of heat over the disc surface, thus minimizing the warp risk of said disc.

The caliper is designed with six separate pockets, each with its own pad, thus rendering them firmly in situ, even though the pads locking pin should fall out, all in the name of safety.

A variety of applications of this caliper have proven possible, two up front on bigger bikes and single on 125:s and drag bikes, as well as in the rear of both drag and custom bikes.

Suitable master cylinder sizes are 17,5 mm for double use, and 14mm for single use.

# ISR

PART NUMBER : 22-042-0A (RH)  
22-042-0B (LH)

22-042-0A

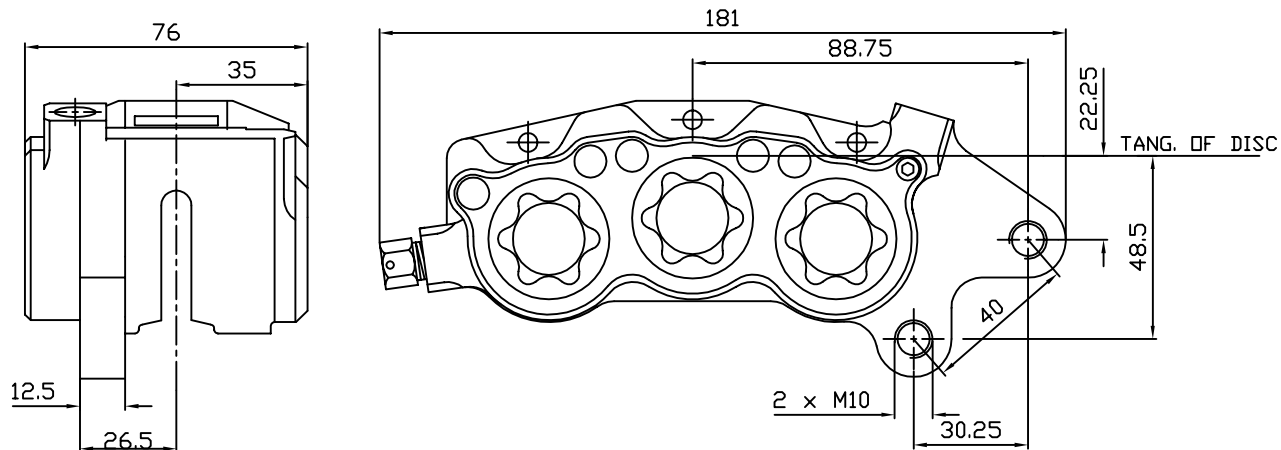

## Technical data:

Piston diameter:	30mm (x6)
Piston material:	Tufam coated aluminium alloy
Pad type:	ISR 29-001 (x6)
Pad area:	31.8cm <sup>2</sup>
Swept height of disc:	33mm
Disc size:	300-320mm
Disc thickness:	4.6-5.0mm
Hydraulic threads:	M10x1.25
Weight incl. pads:	0.94kg
Surface finish:	Clear anodised

# ISR

PART NUMBER : 22-042-0C (RH)  
22-042-0D (LH)

22-042-0C BREMBO 65mm

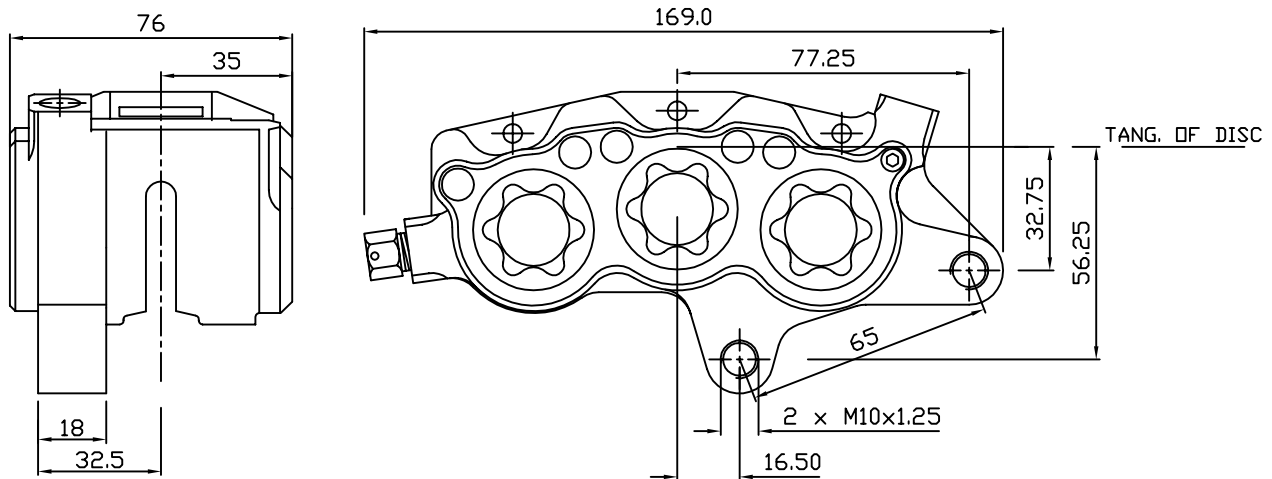

## Technical data:

Piston diameter:	30mm (x6)
Piston material:	Tufram coated aluminium alloy
Pad type:	ISR 29-001 (x6)
Pad area:	31.8cm <sup>2</sup>
Swept height of disc:	33mm
Disc size:	300-320mm
Disc thickness:	4.6-5.0mm
Hydraulic threads:	M10x1.25
Weight incl. pads:	0.94kg
Surface finish:	Clear anodised



# 22-043-0A

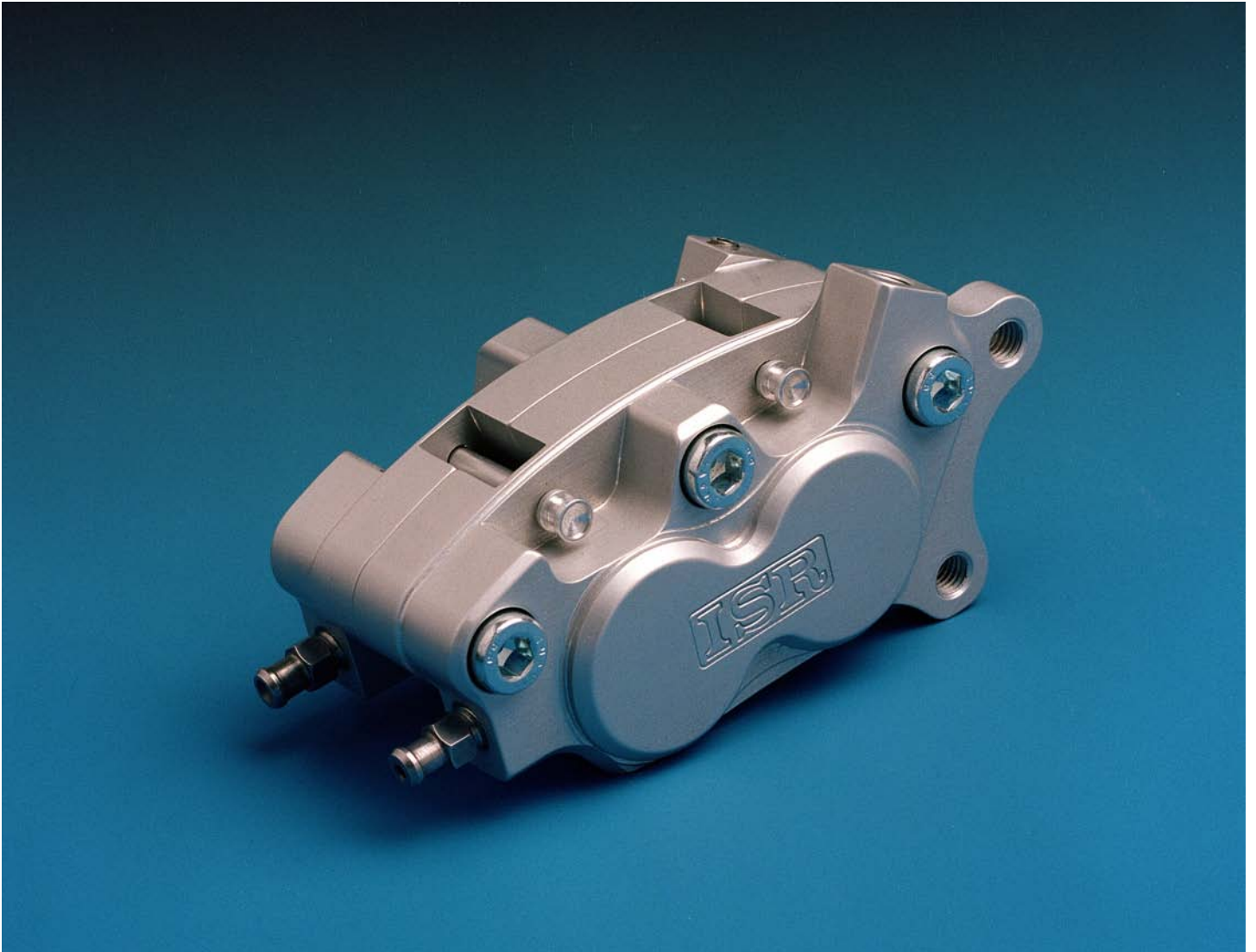

**T**his caliper was at first intended for chopper use . The advantage over the 22-028 calipers is the reduced swept height at a large effective mean radius .

This makes for a low weight disc “with a lot of air in it” as per our 23B-HD220-01 disc , or 13-020-OA wheel hub.

# ISR

PART NUMBER : 22-043-0A (RH)  
22-043-0B (LH)

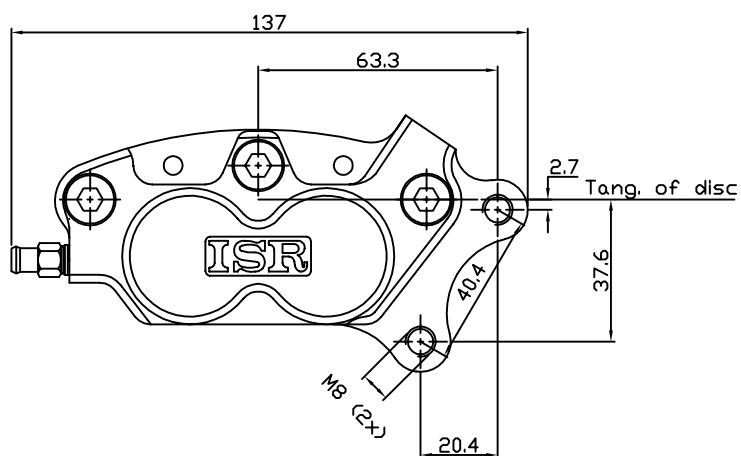
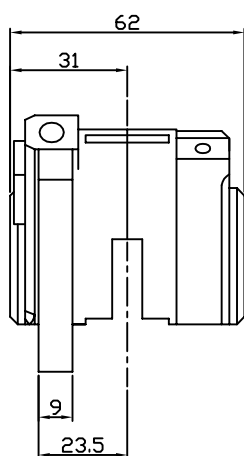

## Technical data:

Piston diameter:	25mm (x4)
Piston material:	Tufram coated aluminium alloy
Pad type:	ISR 29-002 (x4)
Pad area:	14cm <sup>2</sup>
Swept height of disc:	27mm
Disc size:	150-280mm
Disc thickness:	4.6-5.0mm
Hydraulic threads:	M8x1
Weight incl. pads:	0.66kg
Surface finish:	Clear anodised



# 22-044-0A

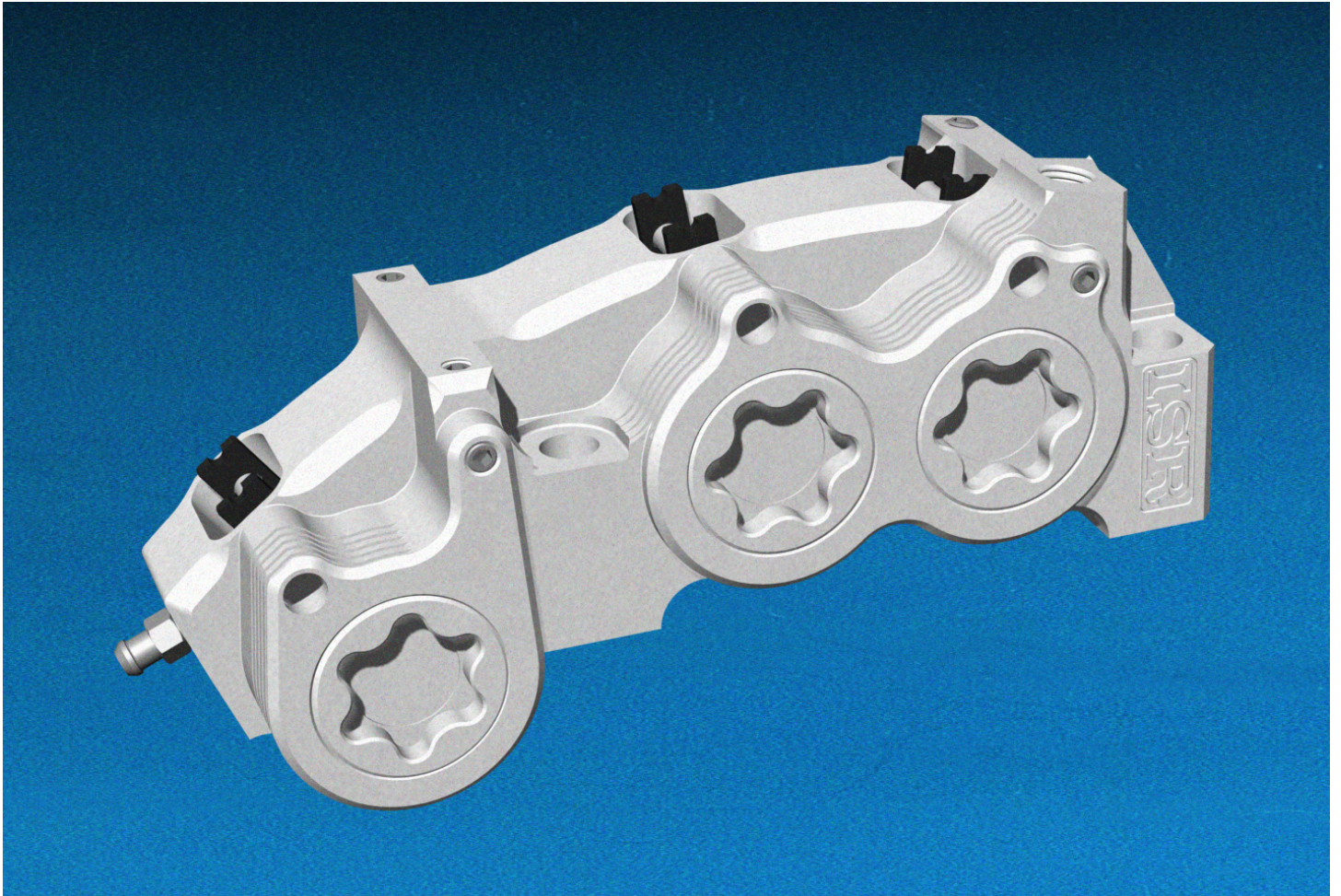

**T**his caliper is intended for use at the highest level of racing, or every where when demands on brakes are extreme.

Uses 108 mm radial bolt pattern.

# ISR

PART NUMBER : 22-044-0A (RH)  
22-044-0B (LH)

22-044-□A

108mm radial boltpattern

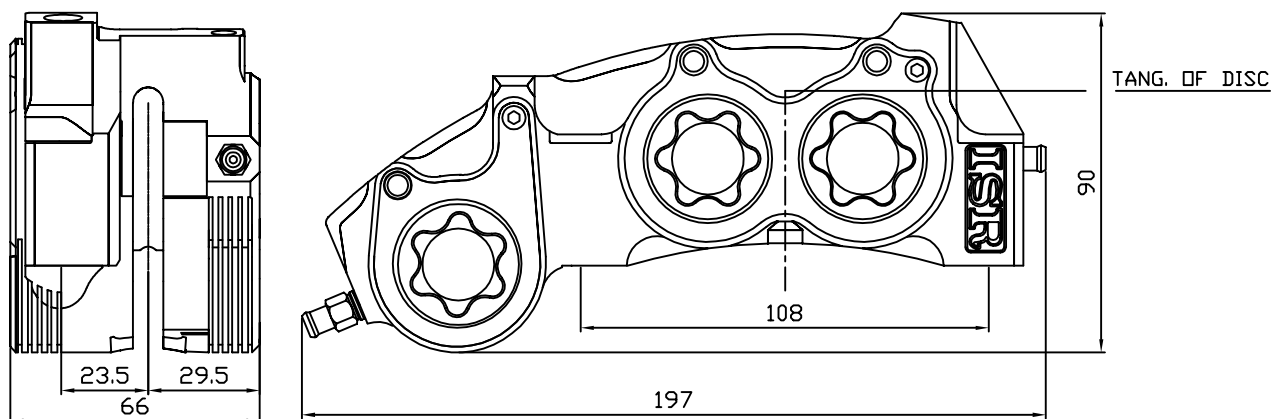

## Technical data:

Piston diameter:	30mm (x6)
Piston material:	Tufram coated aluminium alloy
Pad type:	ISR 29-001 (x6)
Pad area:	31.8cm <sup>2</sup>
Swept height of disc:	33mm
Disc size:	320mm
Disc thickness:	4.6-5.0mm
Hydraulic threads:	M10x1.25
Weight incl. pads:	1.10kg
Surface finish:	Clear anodised



**S**ix piston sprocket caliper, with integrated bracket, for use in the combined sprocket/disc unit which leaves the other side of the wheel free and uncluttered from assorted brake paraphernalia.

21-009 is the recommended master cylinder for this caliper.

# ISR

PART NUMBER : 22-046-0A

22-046-0A

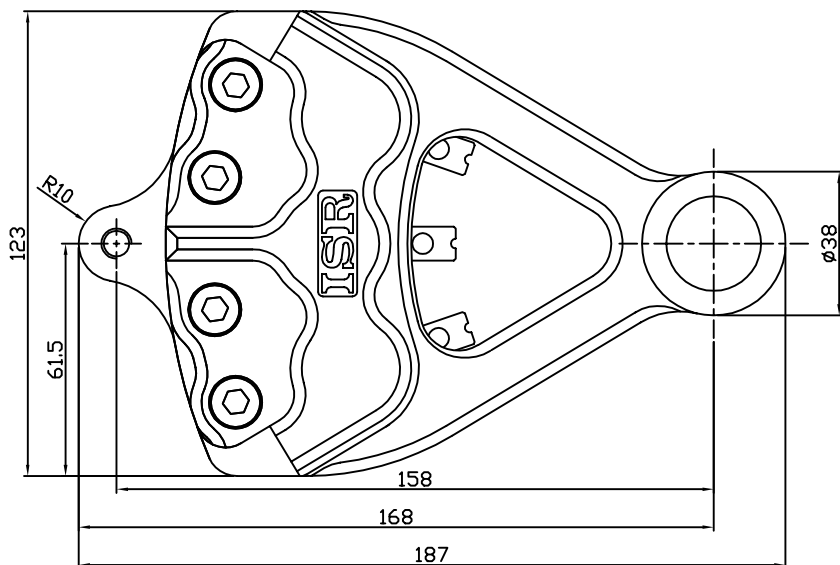
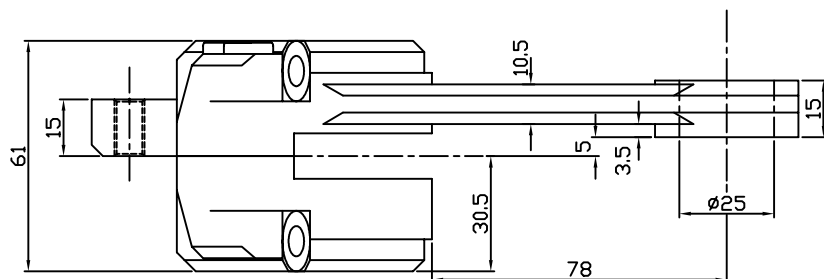

## Technical data:

Piston diameter:	25mm (x6)
Piston material:	Tufram coated aluminium alloy
Pad type:	ISR 29-002 (x6)
Pad area:	20.9cm <sup>2</sup>
Swept height of disc:	27mm
Sprocket size:	ISR 23E-480-02 (48 teeth)
Disc thickness:	9mm (530-sprocket)
Hydraulic threads:	M8x1
Weight incl. pads:	1.05 kg
Surface finish:	Clear anodised

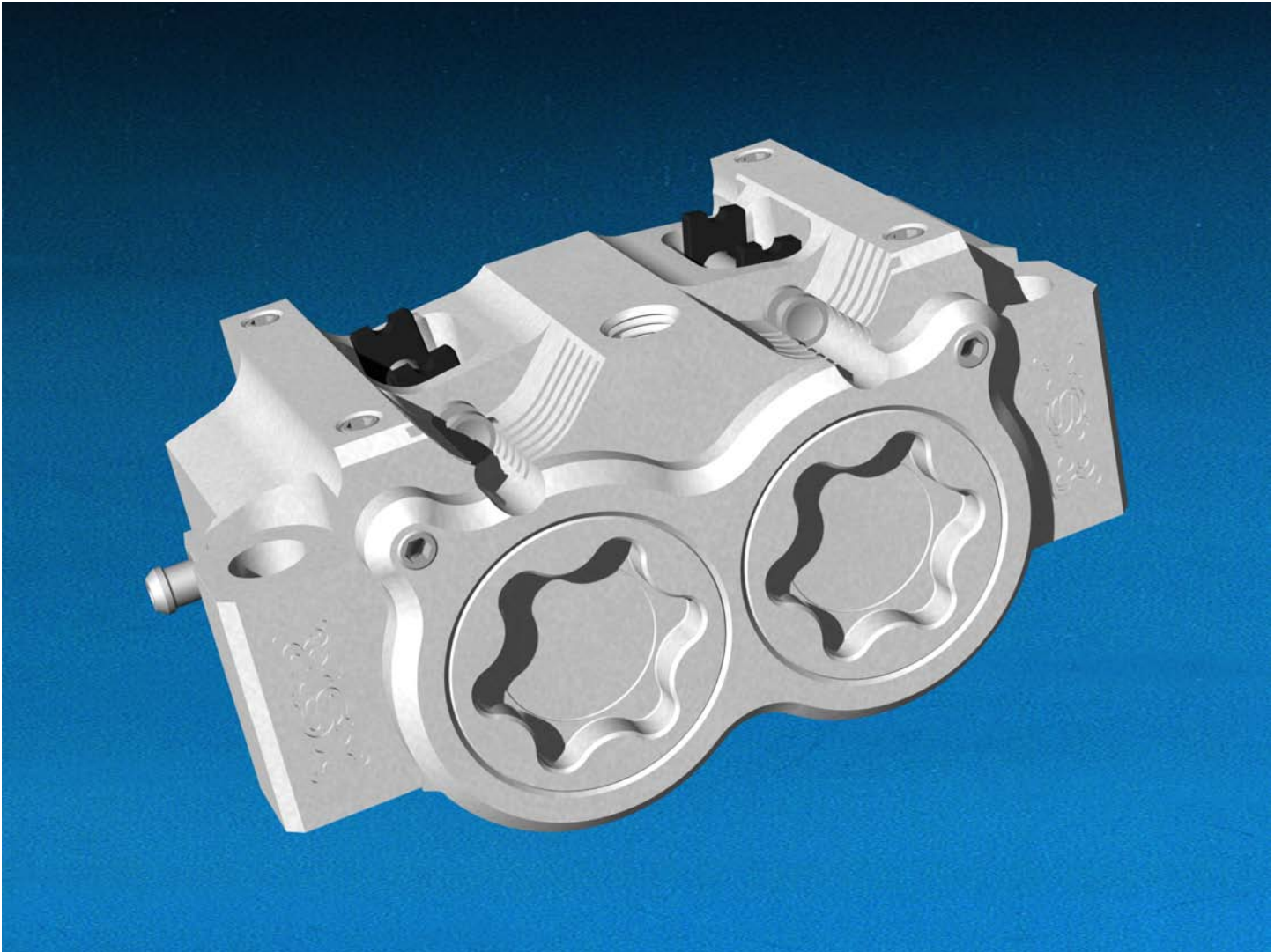

**T**his small and handy 4-piston caliper can be used on street or track.  
It have the almost universal 108mm boltpattern.  
Can be used lefthand or righthand

# ISR

PART NUMBER : 22-047-0A

22-047-0A

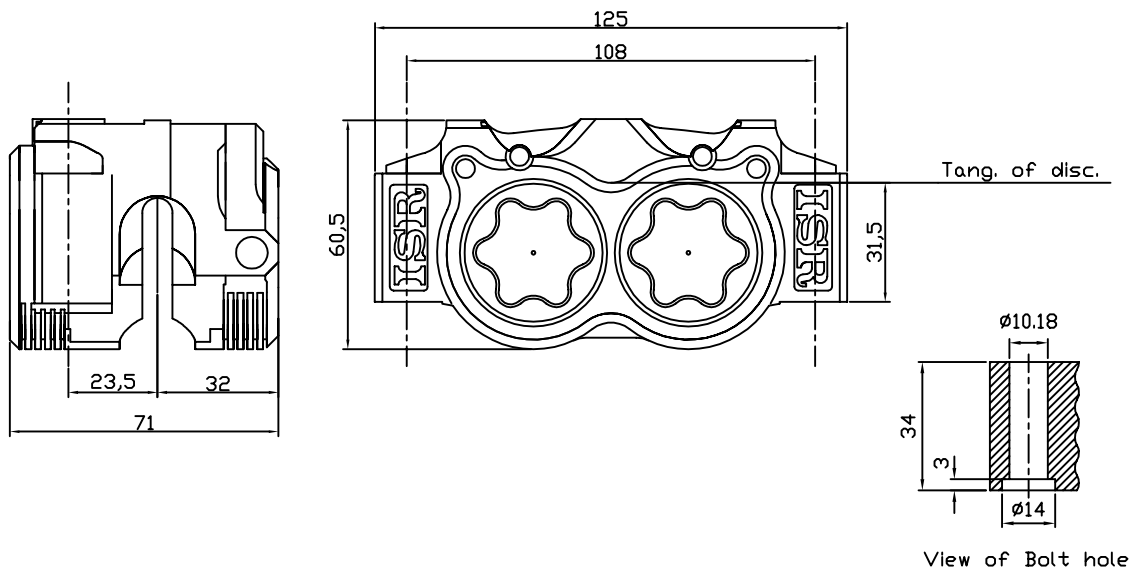

## Technical data:

Piston diameter:	34mm (x4)
Piston material:	Tufram coated aluminium alloy
Pad type:	ISR 29-001 (x4)
Pad area:	21.8cm <sup>2</sup>
Swept height of disc:	33mm
Disc size:	280-320mm
Disc thickness:	4.6-5.0mm
Hydraulic threads:	M10x1.25
Weight incl. pads:	0.80kg
Surface finish:	Clear anodised



# 22-048 Family

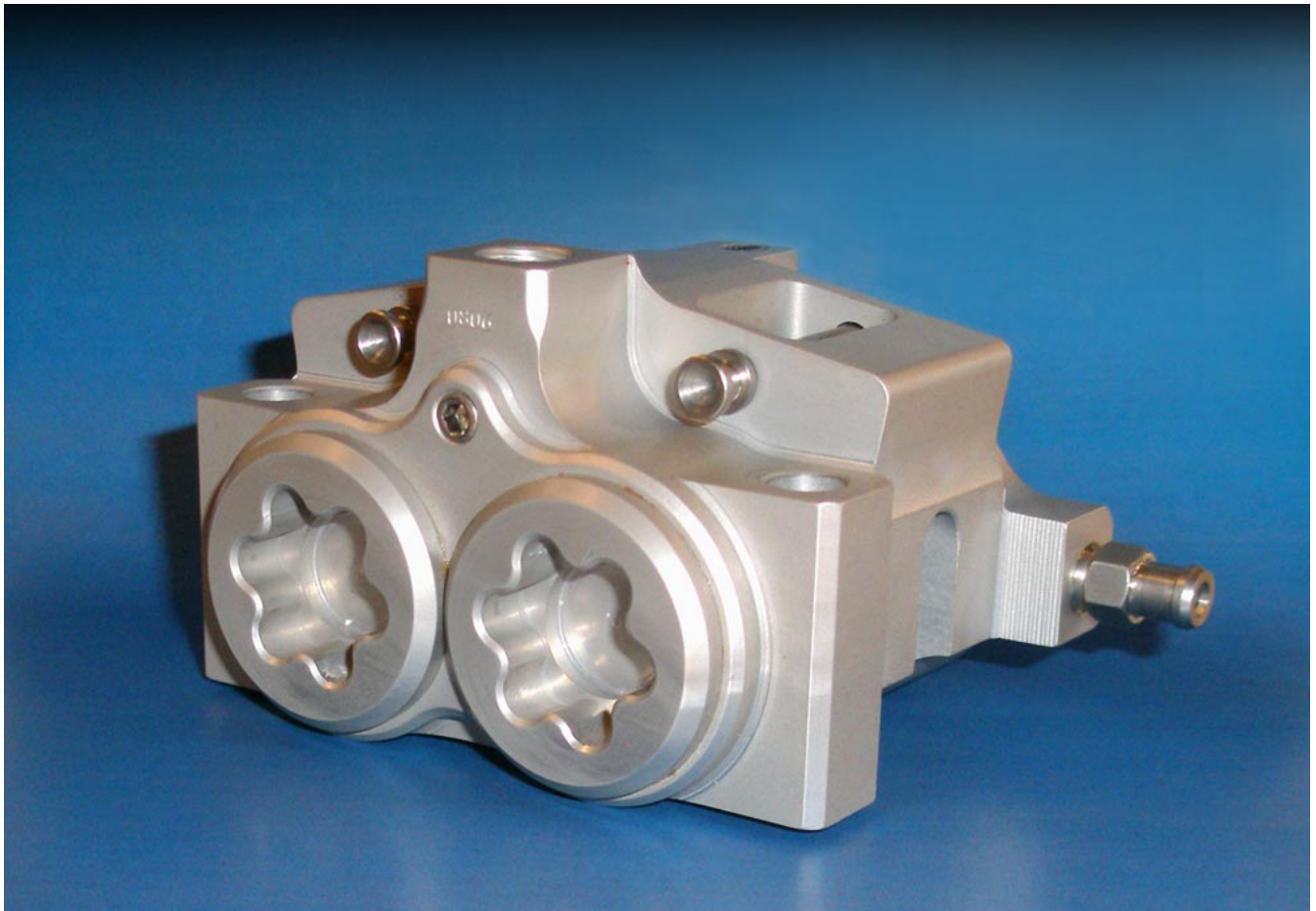

22-048-OA

**T**his light weight 4-piston caliper was designed to be used in a two caliper brake system for 125cc bikes. But it was also intended as a brake caliper for light weight cars, as Formula SAE cars. The car version of the caliper has the brake fluid inlet in one of the caps (22-048-OB).

Can be used lefthand or righthand

The 22-048 is available in both radial and axial mounted version.

# ISR

PART NUMBER : 22-048-0A

22-048-0A

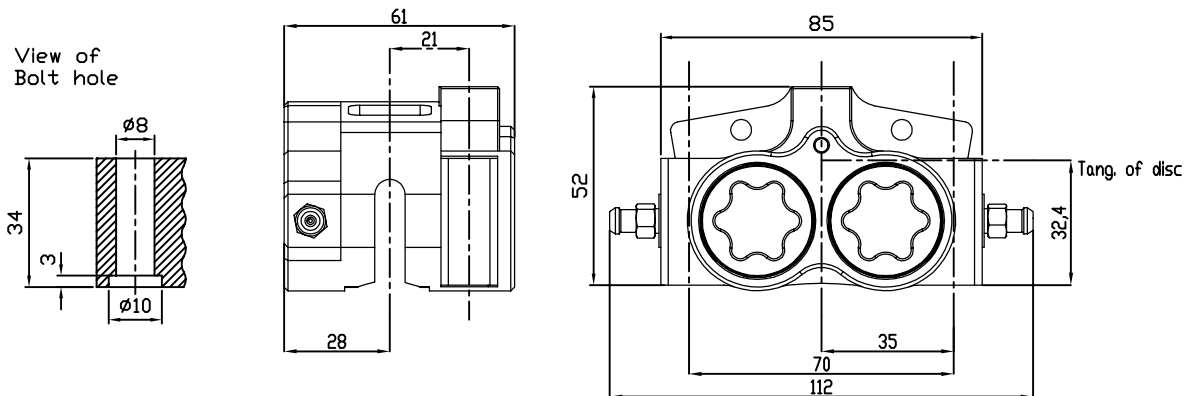

## Technical data:

Piston diameter:	25mm (x4)
Piston material:	Tufram coated aluminium alloy
Pad type:	ISR 29-002 (x4)
Pad area:	20.9cm <sup>2</sup>
Swept height of disc:	27mm
Disc size:	150-250mm
Disc thickness:	4.6-5.0mm
Hydraulic threads:	M10x1.25
Weight incl. pads:	0.46kg
Surface finish:	Clear anodised

# ISR

PART NUMBER : 22-048-0B

22-048-0B

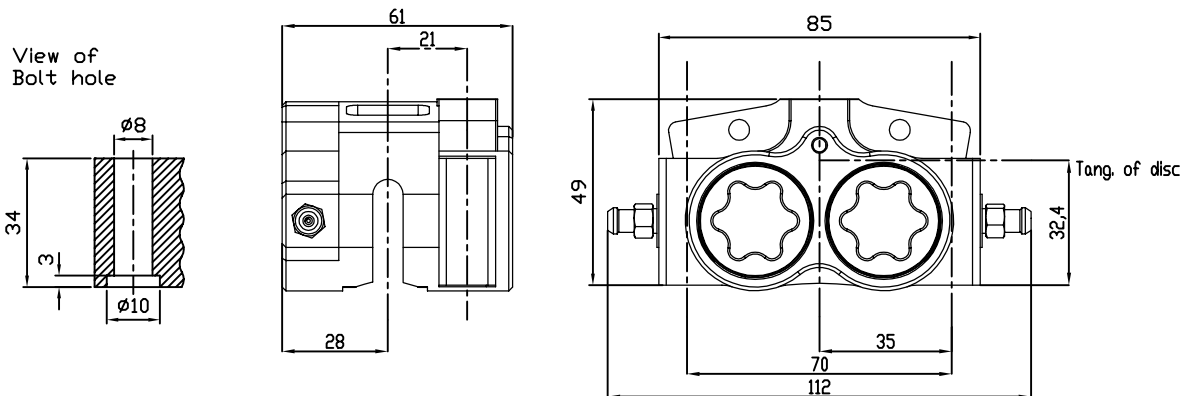

## Technical data:

Piston diameter:	25mm (x4)
Piston material:	Tufram coated aluminium alloy
Pad type:	ISR 29-002 (x4)
Pad area:	20.9cm <sup>2</sup>
Swept height of disc:	27mm
Disc size:	150-250mm
Disc thickness:	4.6-5.0mm
Hydraulic threads:	M10x1.25
Weight incl. pads:	0.46kg
Surface finish:	Clear anodised

# ISR

PART NUMBER : 22-048-0C

22-048-0C

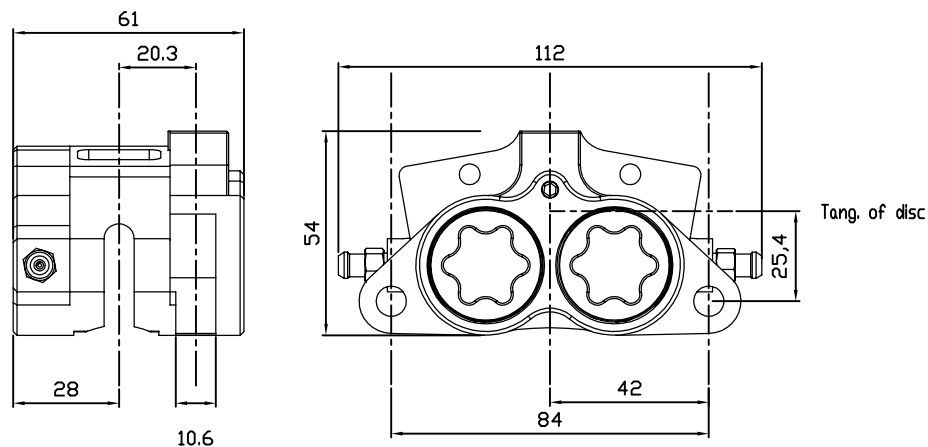

## Technical data:

Piston diameter:	25mm (x4)
Piston material:	Tufram coated aluminium alloy
Pad type:	ISR 29-002 (x4)
Pad area:	20.9cm <sup>2</sup>
Swept height of disc:	27mm
Disc size:	150-250mm
Disc thickness:	4.6-5.0mm
Hydraulic threads:	M10x1.25
Weight incl. pads:	0.46kg
Surface finish:	Clear anodised

# ISR

PART NUMBER : 22-049-0A (RH)  
22-049-0B (LH)

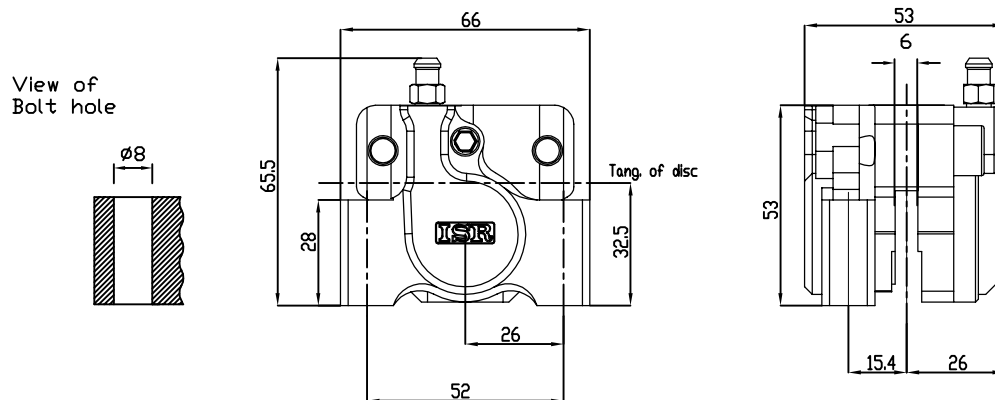

## Technical data:

Piston diameter:	25mm (x2)
Piston material:	Tufram coated aluminium alloy
Pad type:	ISR 29-002 (x2)
Pad area:	20.9cm <sup>2</sup>
Swept height of disc:	27mm
Disc size:	-270mm
Disc thickness:	3-5.0mm
Hydraulic threads:	M10x1.25
Weight incl. pads:	0.26kg
Surface finish:	Clear anodised



22-KSMHO-01  
22-KSMKA-01  
22-KSMSU-01  
22-KSMYA-01

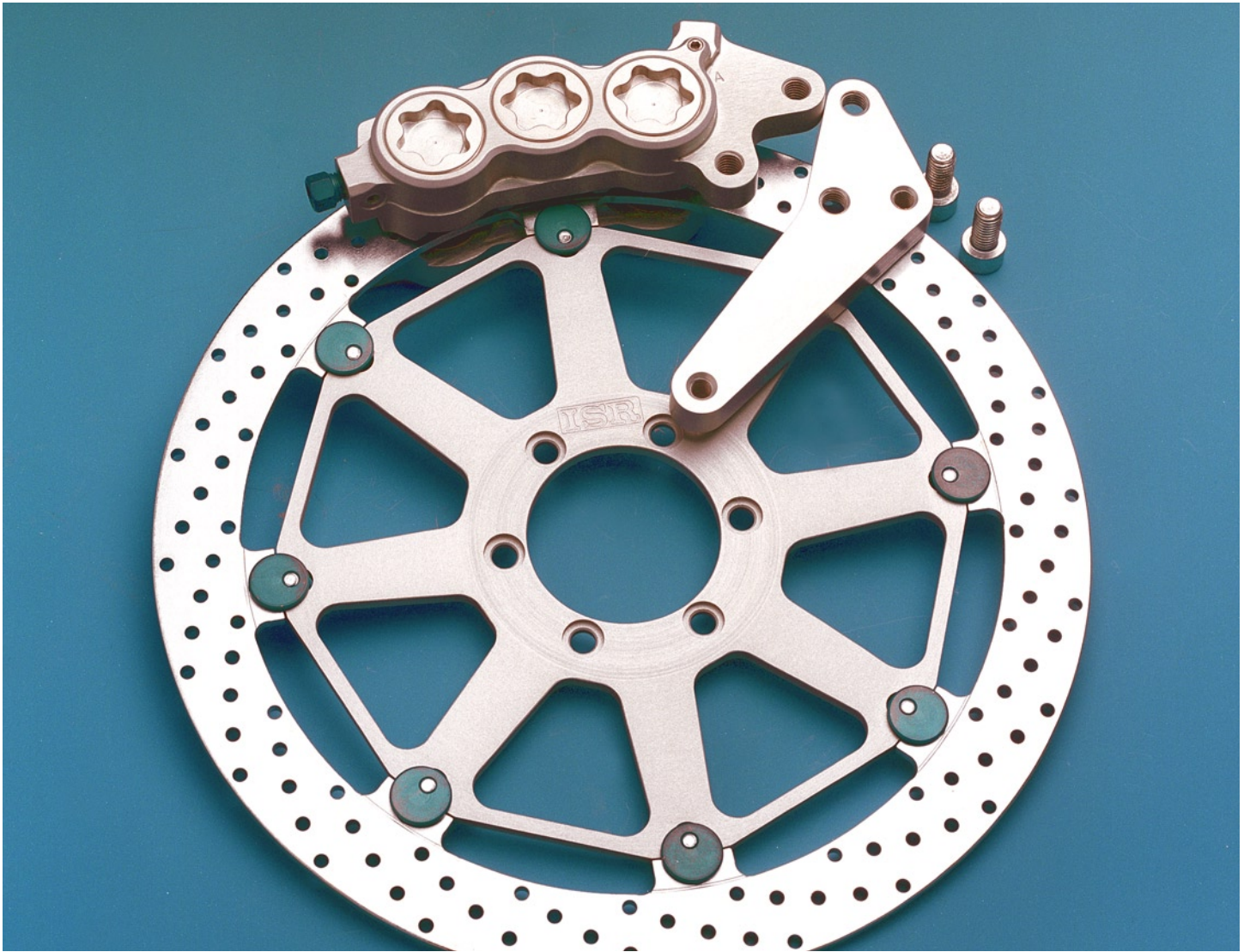

**S**uper**M**otard kit for Japanese bikes . Should a non standard wheel be selected we can always help with whatever bolt pattern and offset is required.

Clearances and data;  
Disc diameter : 320mm  
Disc-center to spoke: 31mm



# 22-KSMHU-01

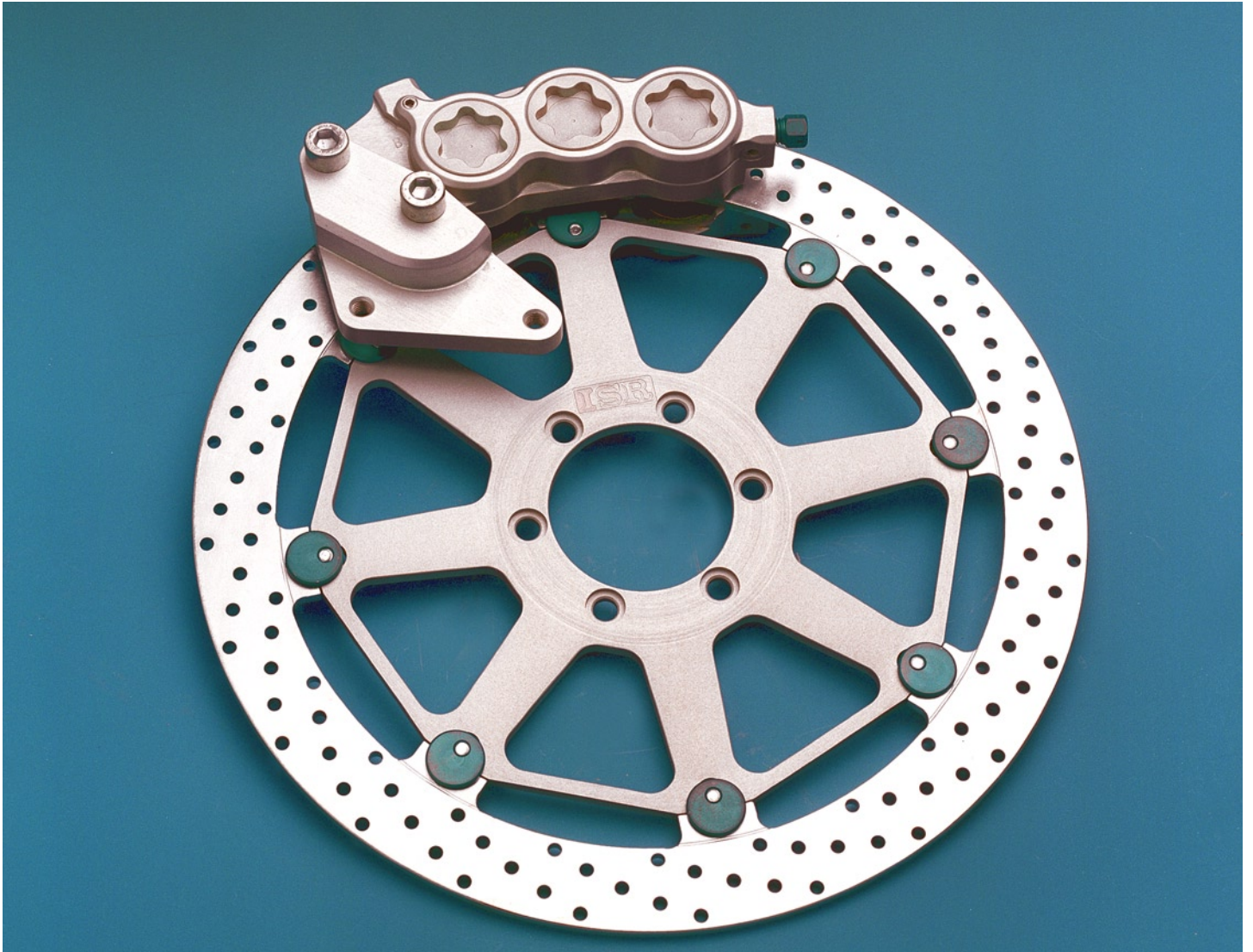

**S**uper**M**otard kit for Husky and other European bikes with WP forks . Should a non standard wheel be selected we can always help with whatever bolt pattern and offset is required.

Clearances and data;  
Disc diameter : 320mm  
Disc-center to spoke: 31mm



# 22-KCSKA-01 & -02

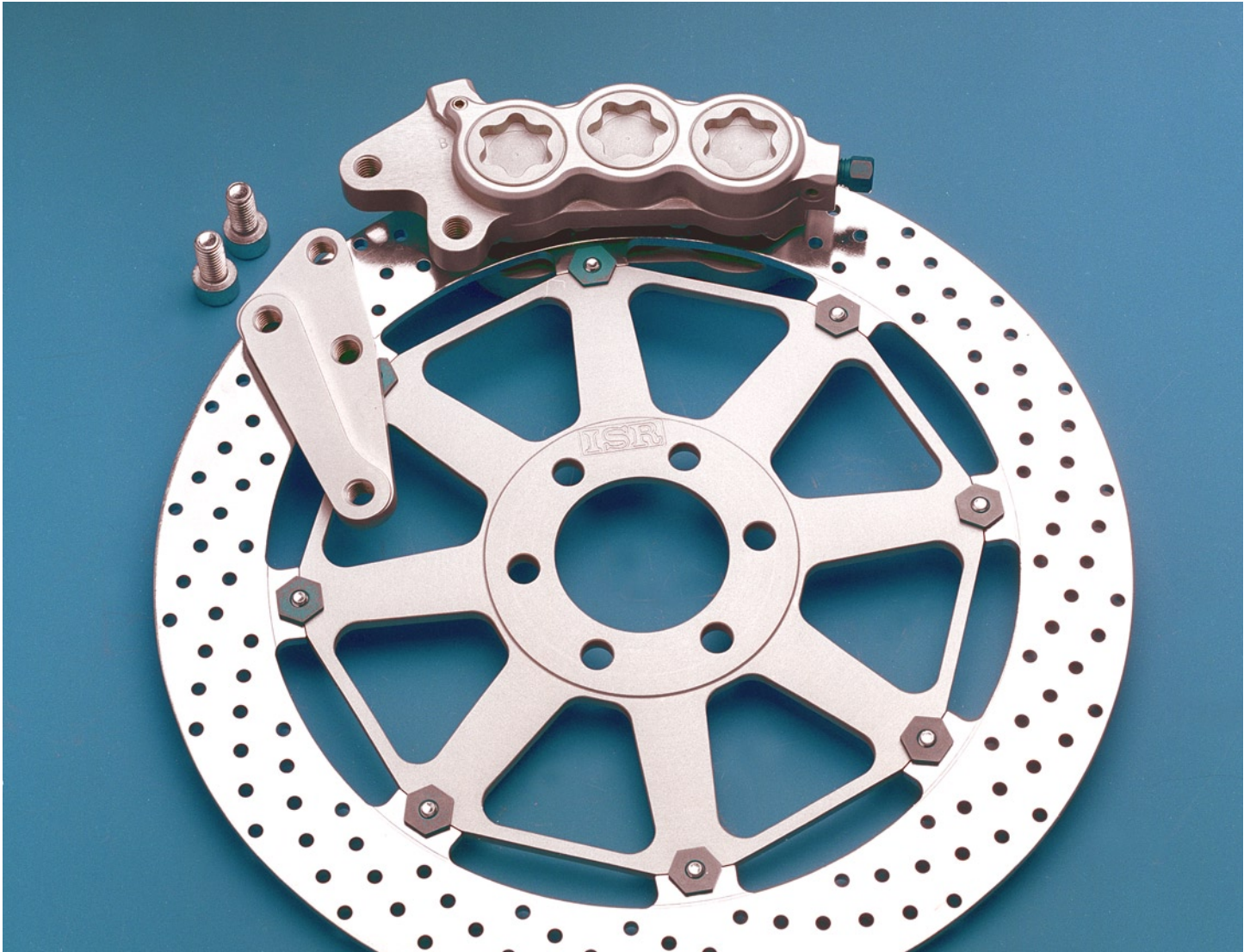

**T**hese kits are to remedy the somewhat under dimensioned brakes of the VN 1500 . Choices can be made insofar calipers are concerned , between six and four piston calipers , all depending upon desired performance.

Disc diameter 320mm

Six piston caliper kit number ends with -01

Four piston caliper kit number ends with -02

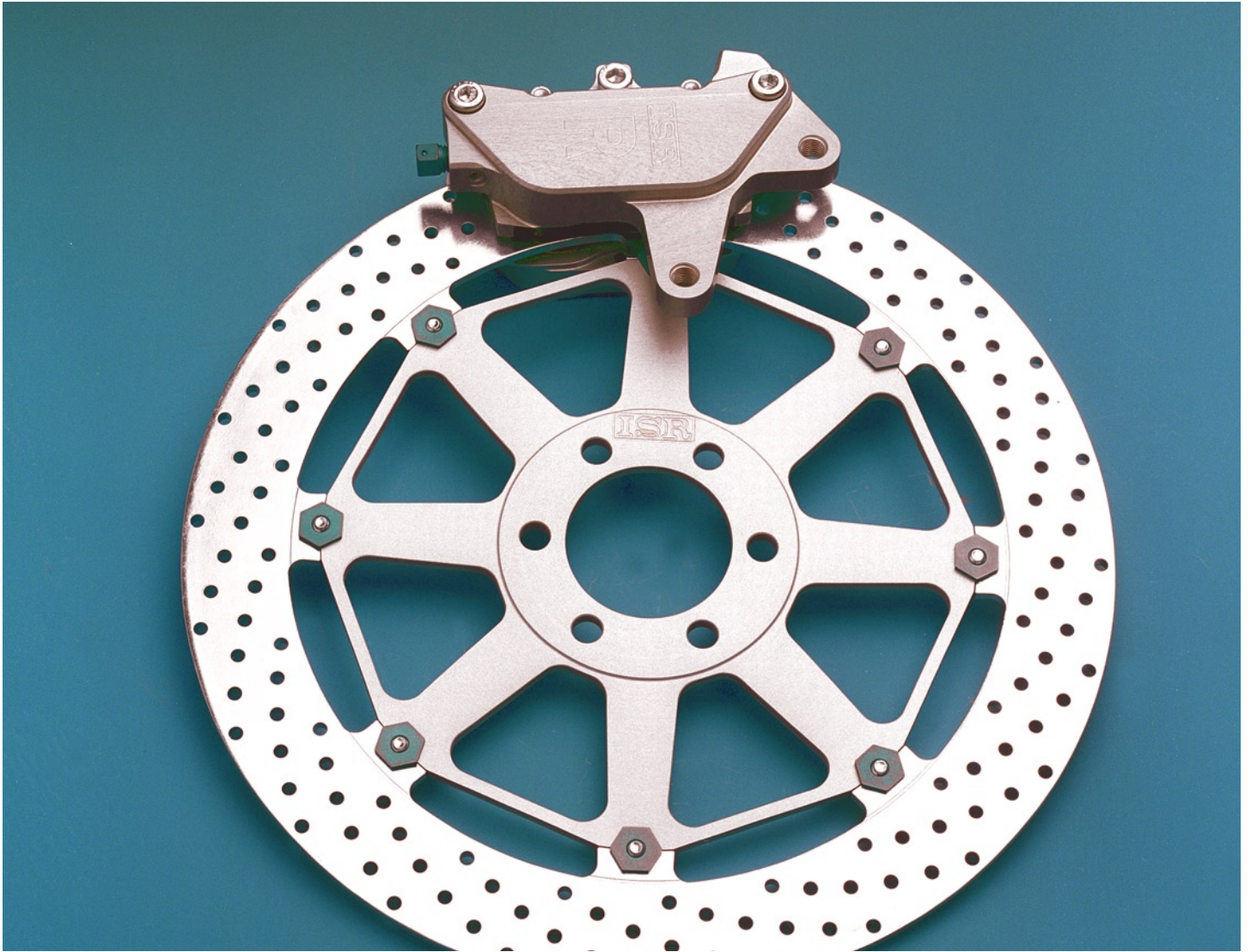

**T**his kit is designed to upgrade the inherently weak brakes of the Suzuki Intruder .

The kit consists of a semi floating 320mm disc and a well proven four piston , four pad, 22-025 type caliper , adopted here for the Intruder fork without bracket , for the cleanest possible look.

All standard Intruder bolts and fittings are applicable.



# The 23-Series Discs

All ISR discs are made to the highest standard, machined out of Swedish steel bar and not out of sheet metal. Our discs are available in five major types. Furthermore, we offer the unique service of custom making discs to whatever size, offset, bolt pattern, et cetera, you the customer, desires. Please refer to our ordering sheet for custom made discs.

**23-A Full Floating Discs** intended for racing and performance oriented use. Unlike a vast majority of discs the ISR disc can be rebuilt to "as new" standard in order to restore disc float to original specifications. If required, as on all the ISR discs, both disc carrier and rotor can be ordered separately. (main picture)

**23-B Semi Floating Discs** to be used on heavier bikes, such as Harleys, Customs and Tourers where the performance and added complication of the full floating disc tends to be somewhat of an overkill.

**23-C One Piece Solid Discs** offering low cost and minor complication level as well as a clean and classic look, not seldom used at the rear of choppers.

**23-D One Piece Discs**, for off road pad savers without affecting performance.

**23-E Sprocket Discs** for use with our sprocket caliper.

**23-F Dampened Full floating Discs**

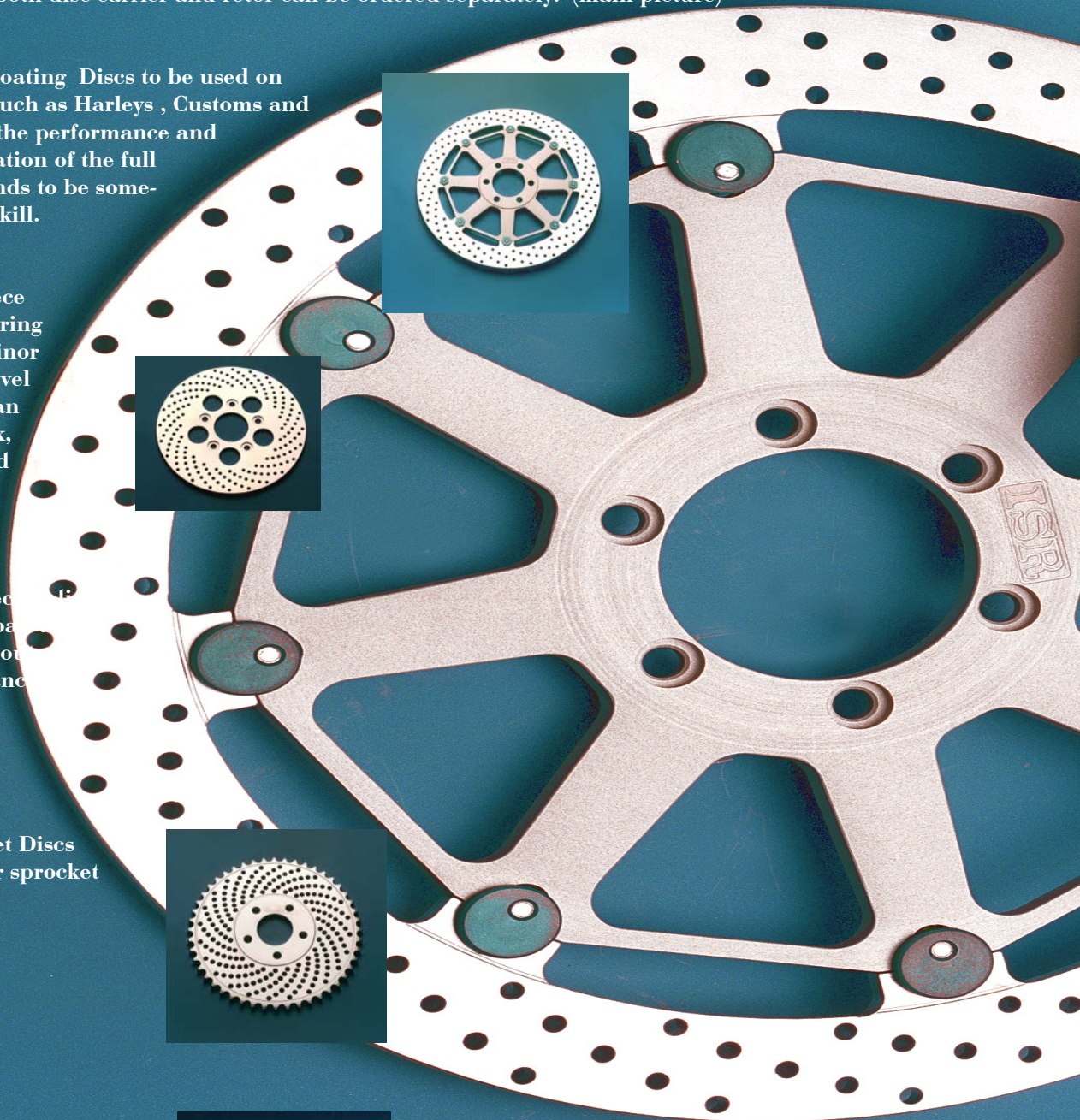



# Discs for Harley-Davidson

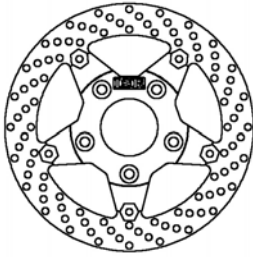

**23B-HD220-01** (FH:27mm)  
Center hole: 50.3mm  
Bolt hole: 8.5mm

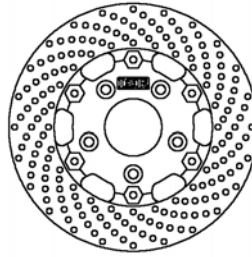

**23B-HD220-02** (FH:40mm)  
Center hole: 50.3mm  
Bolt hole: 8.5mm

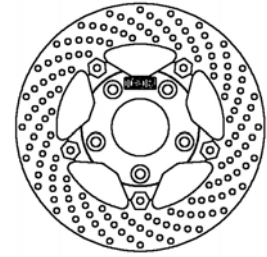

**23B-HD220-03** (FH:35mm)  
Center hole: 50.3mm  
Bolt hole: 8.5mm

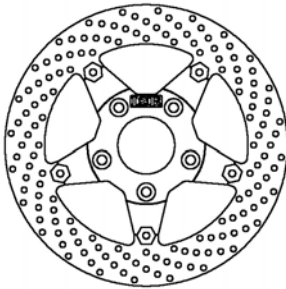

**23B-HD250-01** (FH:35mm)  
Center hole: 50.3mm  
Bolt hole: 8.5mm

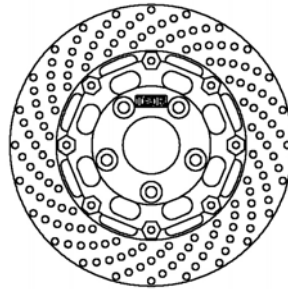

**23B-HD250-03** (FH:41mm)  
Center hole: 50.3mm  
Bolt hole: 10.5mm

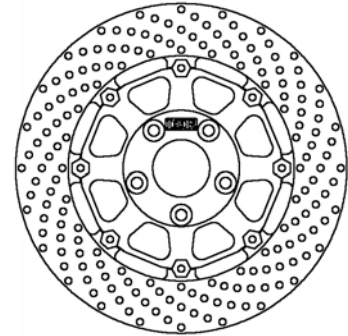

**23B-HD293-02** (FH:45mm)  
Center hole: 50.3mm  
Bolt hole: 10.5mm

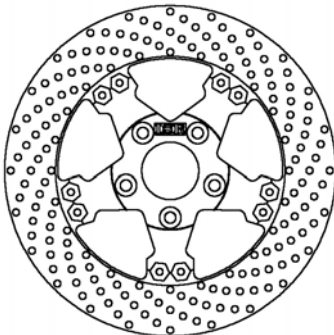

**23B-HD293-03** (FH:45mm)  
Center hole: 50.3mm  
Bolt hole: 10.5mm

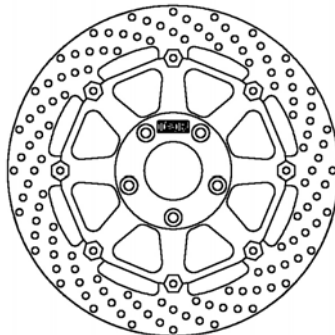

**23B-HD293-04** (FH:35mm)  
Center hole: 50.3mm  
Bolt hole: 8.5mm

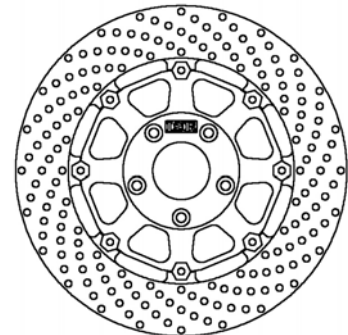

**23B-HD293-05** (FH:45mm)  
Center hole: 50.3mm  
Bolt hole: 8.5mm



# Discs for Harley-Davidson

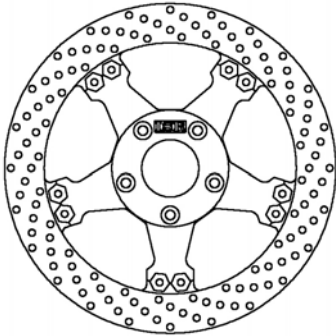

**23B-HD293-06** (FH:35mm)  
Center hole: 50.3mm  
Bolt hole: 8.5mm

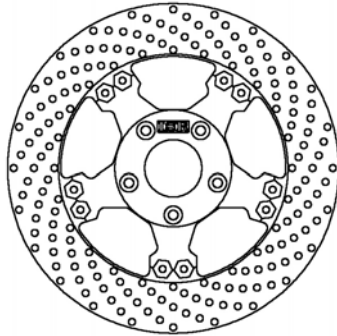

**23B-HD293-07** (FH:45mm)  
Center hole: 50.3mm  
Bolt hole: 8.5mm

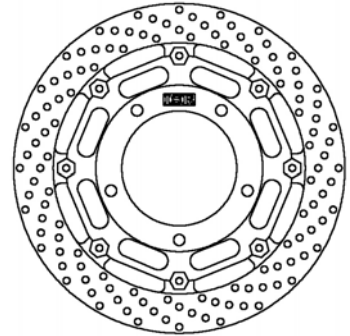

**23B-HD293-08** (FH:35mm)  
Center hole: 101.7mm  
Bolt hole: 10.5mm

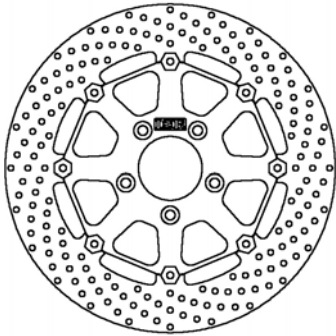

**23B-HD293-10** (FH:41mm)  
Center hole: 56.35mm  
Bolt hole: 8.5mm

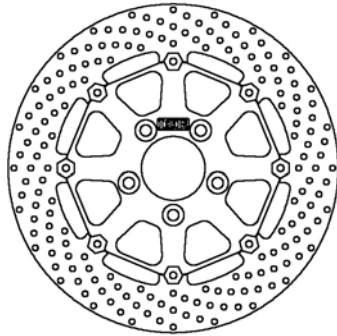

**23B-HD293-11** (FH:41mm)  
Center hole: 56.35mm  
Bolt hole: 10.5mm

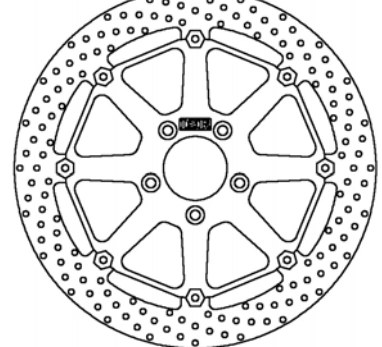

**23B-HD320-02** (FH:35mm)  
Center hole: 56.35mm  
Bolt hole: 8.5mm

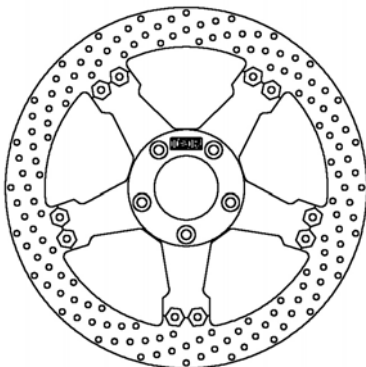

**23B-HD320-03** (FH:35mm)  
Center hole: 56.35mm  
Bolt hole: 8.5mm

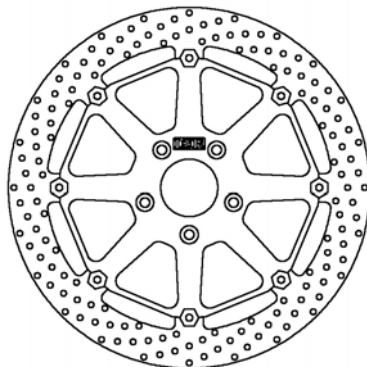

**23B-HD320-09** (FH:35mm)  
Center hole: 50.3mm  
Bolt hole: 8.5mm

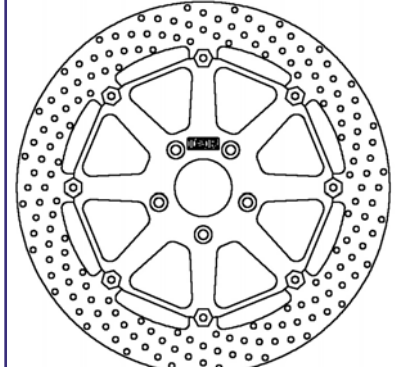

**23B-HD330-10** (FH:38.5mm)  
Center hole: 50.3mm  
Bolt hole: 8.5mm



# 71-003-0A-AA



**T**his clutch lever assembly is intended for Harley , it takes the standard issue clutch cable used on the five speed gearbox. It is shown both with the adjustable reach lever 71-104-0A , and with the standard lever. It comes with M12x1 thread for the rear view mirror .

# ISR

PART NUMBER : 71-003-0A (LH)

## WIRE CLUTCH FOR HD

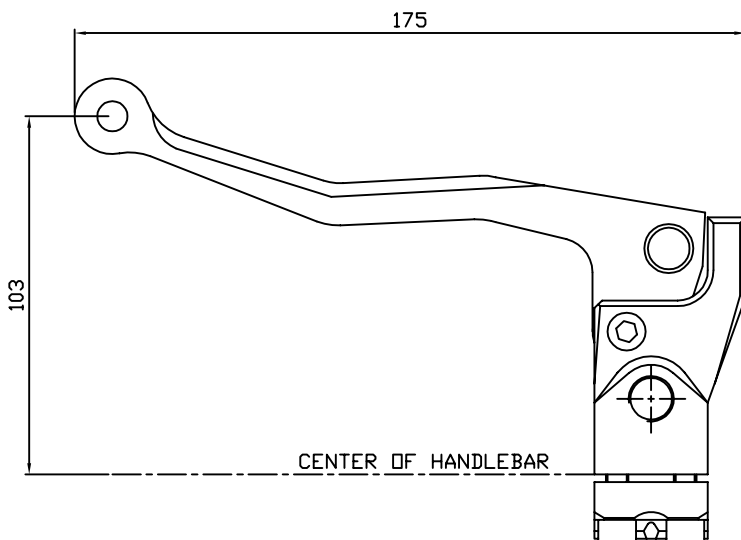
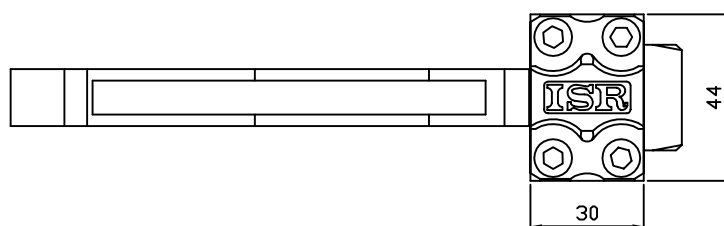

### Technical data:

Mirror thread:	M12x1
Weight:	0.26kg
Surface finish:	Clear anodised
Handlebar size:	Ø25.4mm



# 71-004-0A-AA



**U**niversal clutch levers for 22mm handlebars . The standard issue adjuster is for a 3,5mm cable. Demands for other cable diameters will be attended to forthwith. The distance between the cable attachment center to the pivot point is 34mm. It is shown here both with standard lever and the adjustable reach lever 71-109-OA.

# ISR

PART NUMBER : 71-004-0A (LH)

## WIRE CLUTCH

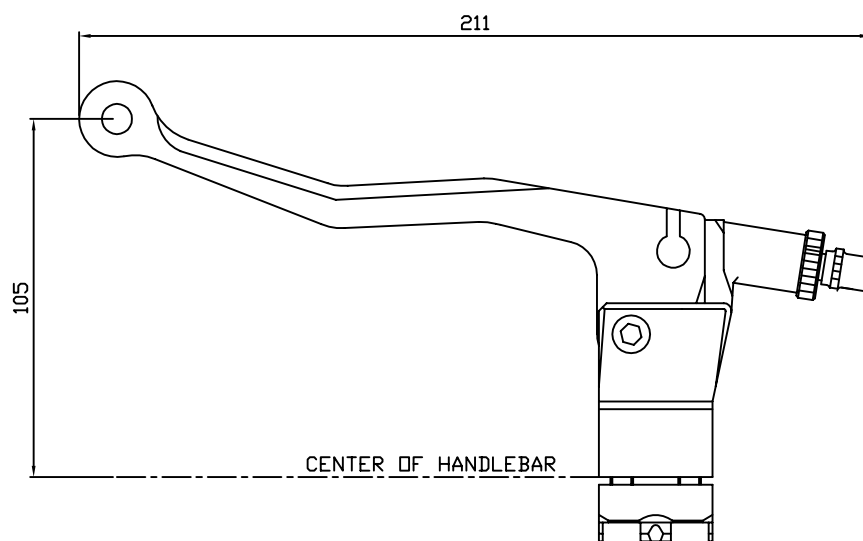
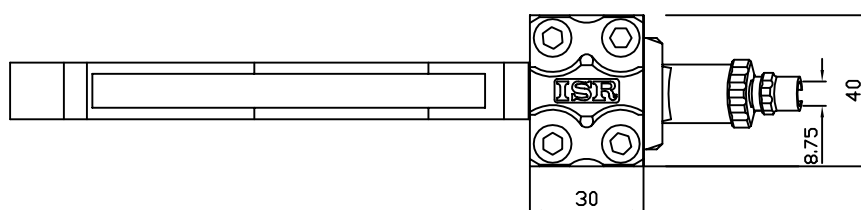

### Technical data:

Wire diameter:	max. 3.5mm
Wire nipple diameter:	8.75mm
Weight:	0.25kg
Surface finish:	Clear anodised
Handlebar size:	Ø22mm



# 71-004-0B-AB

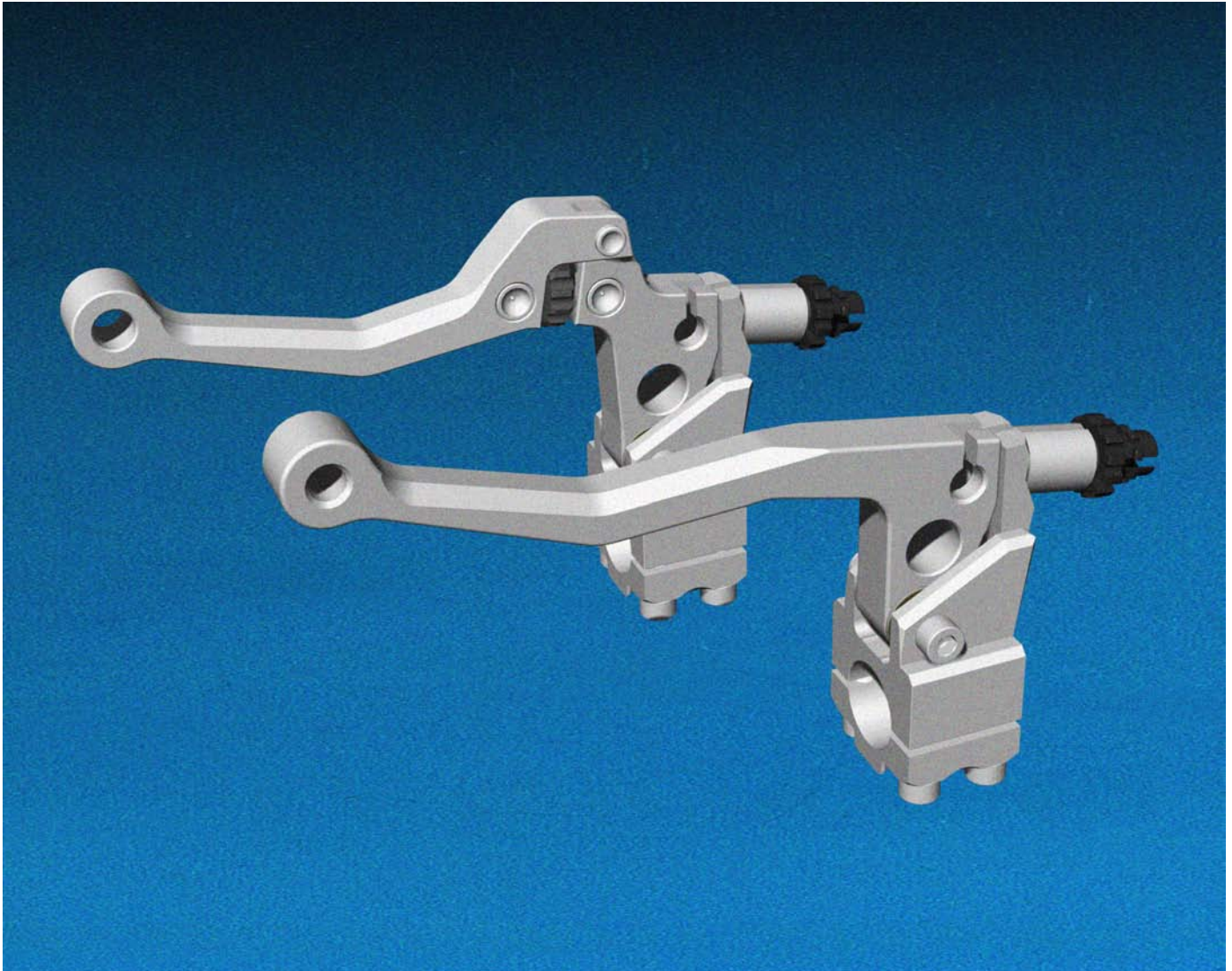

**U**niversal clutch levers for 22mm handlebars, with increased cable pull.  
The distance between the cable attachment center to the pivot point is 34mm.  
The standard issue adjuster is for a 3,5mm cable.  
Demands for other cable diameters will be attended to forthwith.  
It is shown here both with standard lever and the adjustable reach lever 71-109-OB.



# Switch clamps



Handlebar clamp Switch assemblies.

Now available for both 25.4mm and 22mm handlebars.

Twelve types are available:	73-101-OA (One Slide- and two Push buttons) RH	(25.4mm)
	73-101-OB (One Slide- and two Push buttons) LH	(25.4mm)
	73-102-OA (One Slide- and one Push button)	(25.4mm)
	73-103-OA (Two Push buttons only)	(25.4mm)
	73-104-OA (One Slide button only)	(25.4mm)
	73-105-OA (One Push button only)	(25.4mm)
	73-106-OA (One Slide- and two Push buttons) RH	(22mm)
	73-106-OB (One Slide- and two Push buttons) LH	(22mm)
	73-107-OA (One Slide- and one Push buttons)	(22mm)
	73-108-OA (Two Push buttons only)	(22mm)
	73-109-OA (One Slide button only)	(22mm)
	73-110-OA (One Push button only)	(22mm)

NOTE! Slide button: Max current 6A  
Push button: Max current 25mA